

Evaluation of Subsystem Clock Oscillation Circuit

[HD64338602R-32P] LQFP(6x5) 0.5mm pitch

Measurement conditions :3.0V



Model :VT-200
 Frequency :Fo=32.768kHz
 Frequency tolerance :dF/Fo= +/-20x10⁶
 Load capacitance :CL=6.0pF
 Equivalent series resistance :R1=50kohm max
 Max. drive level :DL=1x10⁶W max
 Level of drivel :DL=0.1x10⁶W typ

FEATURES

- 1.Compact tubular package
- 2.Photolithographic process
- 3.Excellent shock resistance and environmental characteristics.
- 4.Real time clocks, Timers, Portable applications

DIMENSIONS(VT-200)

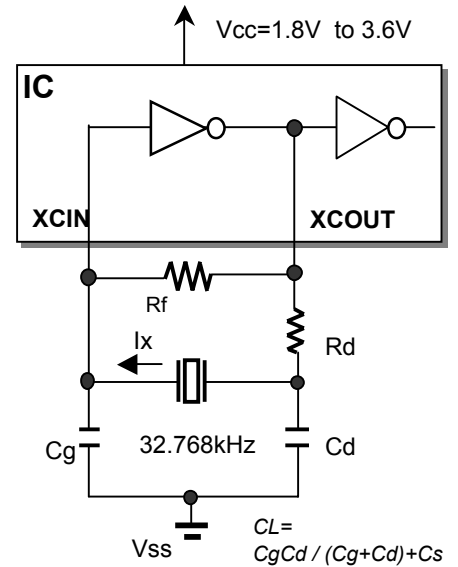
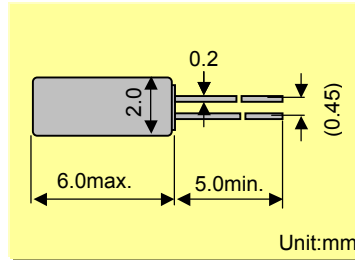

Remark) Ix : current through crystal

The gain of H8/38602R subclock oscillation circuit is different when the circuit is in reset status and in reset-off status. In this report, H8/38068R is evaluated by method1(in reset status: L) and method2(in reset-off status: H).

MODEL:VT-200 6.0pF with HD64338602R at 25°C

Key specifications	RESET_H	RESET_L	Remarks
Negative feedback resistance : Rf (M ohm)	open	open	
Current control resistance : Rd (k ohm)	0	0	Control drive level & secure phase margin
Capacitance at gate : Cg (pF)	2	6	Optimal capacity in response to CL
Capacitance at drain : Cd (pF)	3	6	(CL = Cd // Cg + stray capacitance)

Circuit characteristics (at 25°C)	RESET_H	RESET_L	Remarks
Matching Accuracy : df / f (x10 ⁻⁶)	0.1	-0.5	Frequency offset volume at specified Vdd
Voltage Fluctuation : +/-df / V (x10 ⁻⁶)	1.9	7.8	Vdd +/-10% (Standard operating voltage range)
Drive Level : DL (x10 ⁻⁶ W)	0.06	0.02	DL=Ix ² Re < 1x10 ⁻⁶ W, Re=R1(1 + Co / CL) ²
Negative resistance : - RL (kohm)	367	1337	5 times larger than R _{1MAX}
Oscillation allowance : M (times)	7.3	26.7	Judgemental standard of oscillation stability
Voltage of oscillation start : Vstart (V)	1.53	1.54	
Voltage of oscillation stop : Vstop (V)	1.32	0.98	
Oscillation start up time : Ts (sec)	0.83	0.62	Time to reach 90% of output level

Temperature characteristics of circuit		RESET_H	RESET_L	Remarks
at -40°C	Variation : df / T (x10 ⁻⁶)	-139	-139	Typ.Tp=25°C (K = -3.5x10 ⁻⁸ / °C ²)
at +85°C	Variation : df / T (x10 ⁻⁶)	-135	-135	Typ.Tp=25°C (K = -3.5x10 ⁻⁸ / °C ²)

The above mentioned value is only for your reference. The value is for the arbitrary samples and does not guarantee the product's characteristics. Please review and check above parameters at customer's end.

Seiko Instruments USA Inc.

2990,West Lomita Blvd., Torrance, CA 90505, U.S.A
 Telephone :+1 310-517-7771 Facsimile :+1 310-517-7792
 Email :crystals@siu-la.com

Seiko Instruments GmbH

Siemensstrasse 9,D-63263 Neu-Isenburg,Germany
 Telephone :+49-6102-297-0 Facsimile :+49-6102-297-320
 Email :info@seiko-instruments.de

Seiko Instruments Inc.

1-8,Nakase,Mihama-ku,Chiba-shi,Chiba 261-8507,Japan
 Facsimile :+81-43-211-8030
 E-mail :component@sii.co.jp

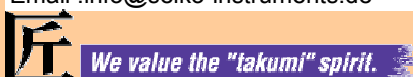

Evaluation of Subsystem Clock Oscillation Circuit

[HD64338602R-32P] LQFP(6x5) 0.5mm pitch
 Measurement conditions :3.0V



Test Data at 25°C

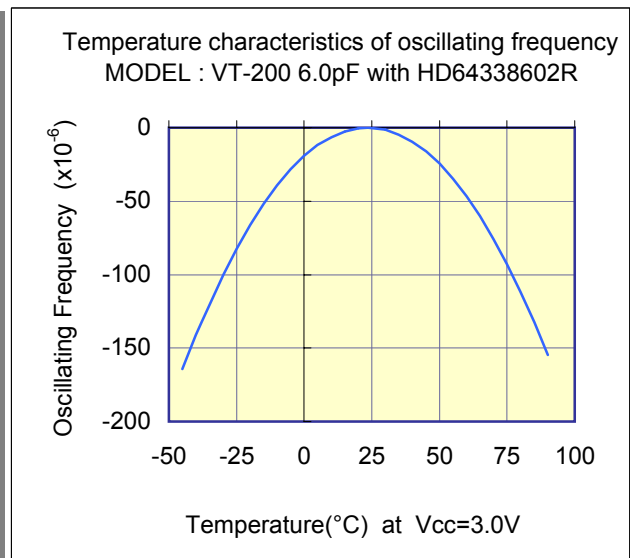
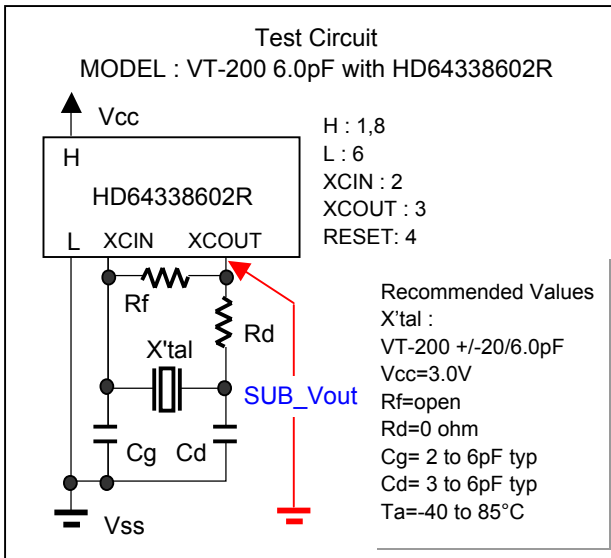
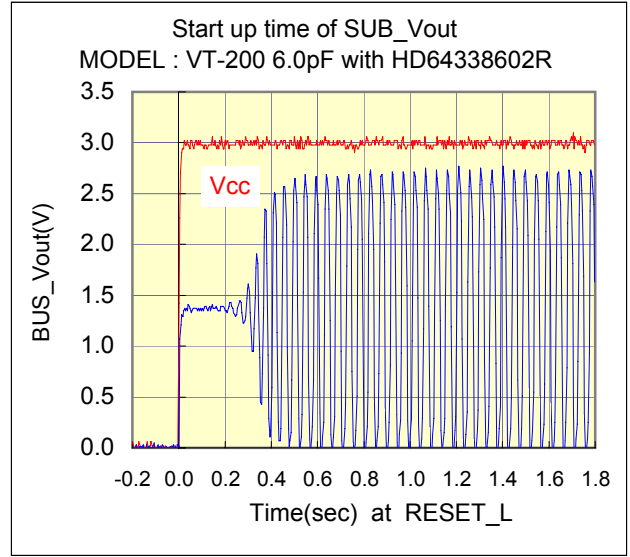
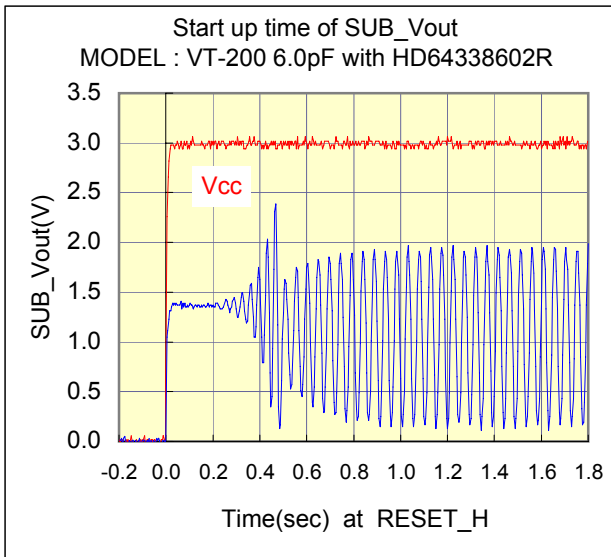
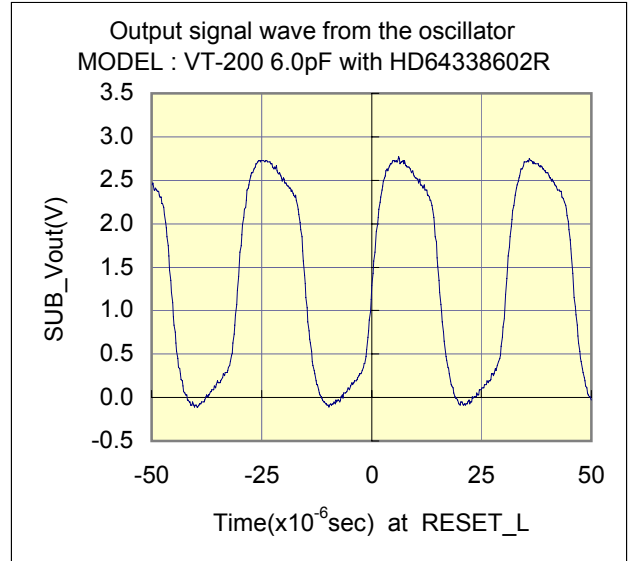
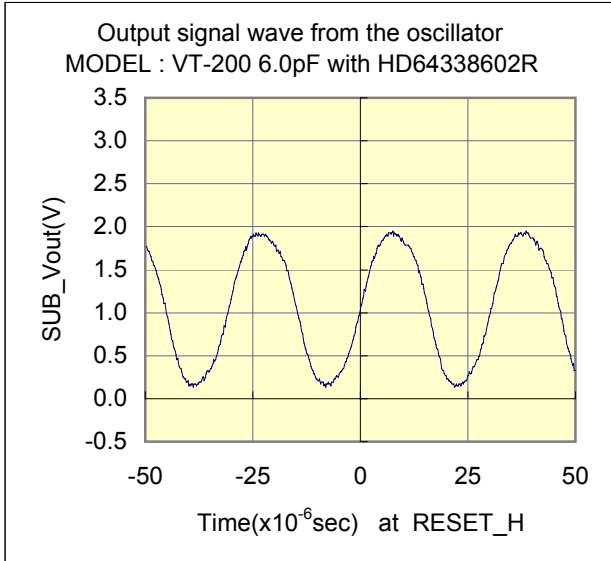

Evaluation of Subsystem Clock Oscillation Circuit

[HD64338602R-32P] LQFP(6x5) 0.5mm pitch
 Measurement conditions :3.0V



Test Data : Temperature characteristics

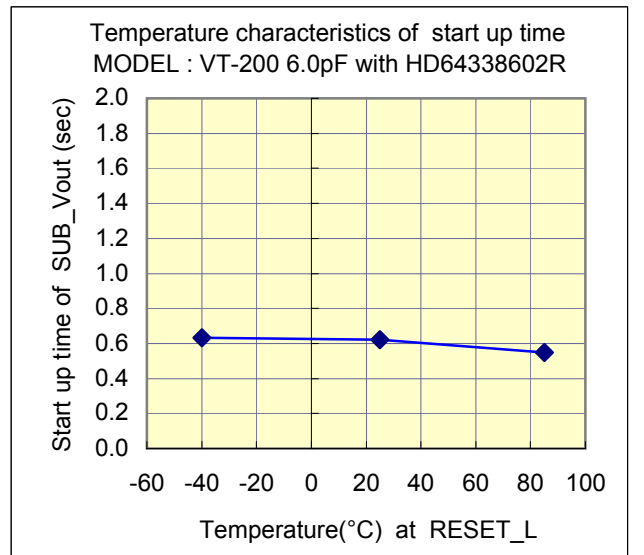
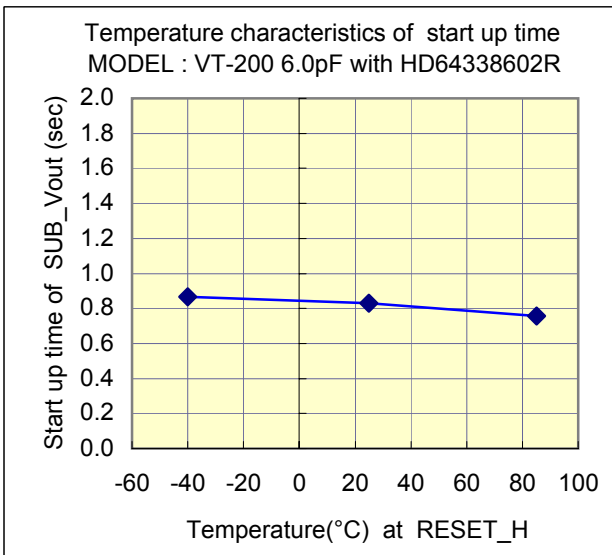
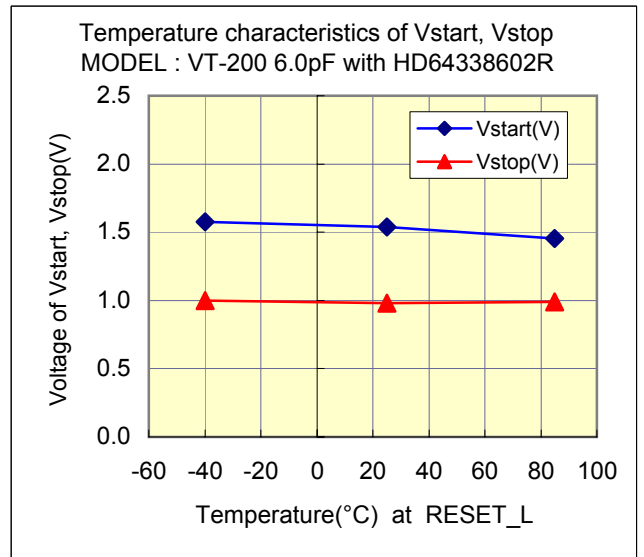
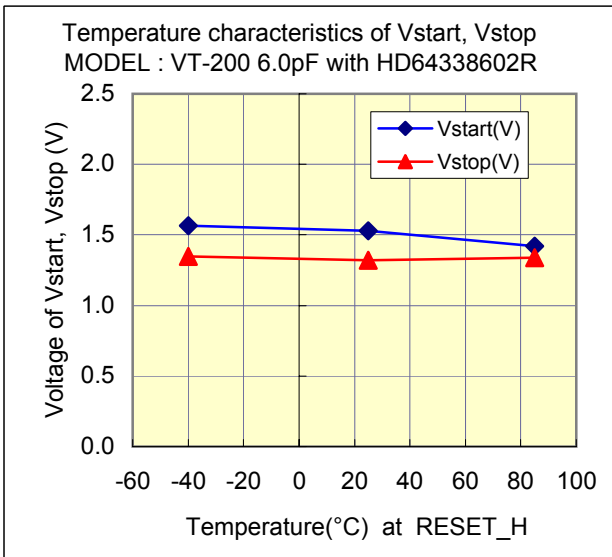
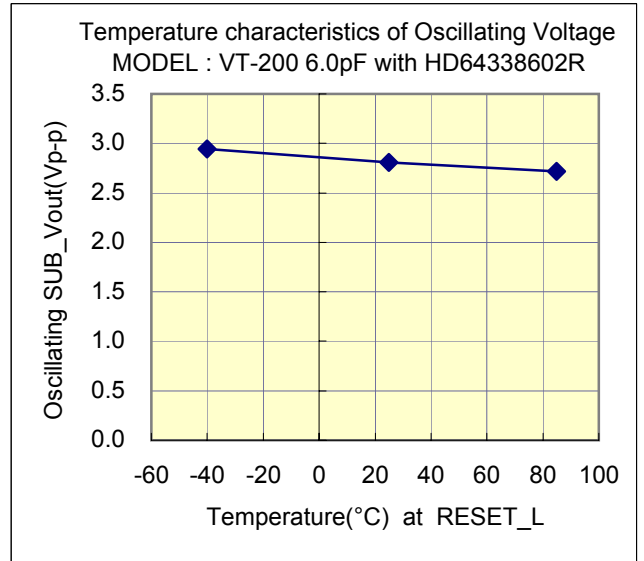
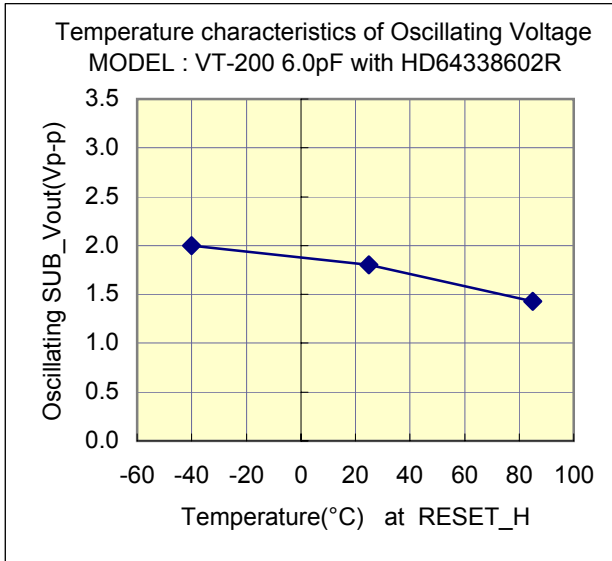

Evaluation of Subsystem Clock Oscillation Circuit

[HD64338602R-32P] LQFP(6x5) 0.5mm pitch
 Measurement conditions :3.0V



Referential components layout(see Figure 1)

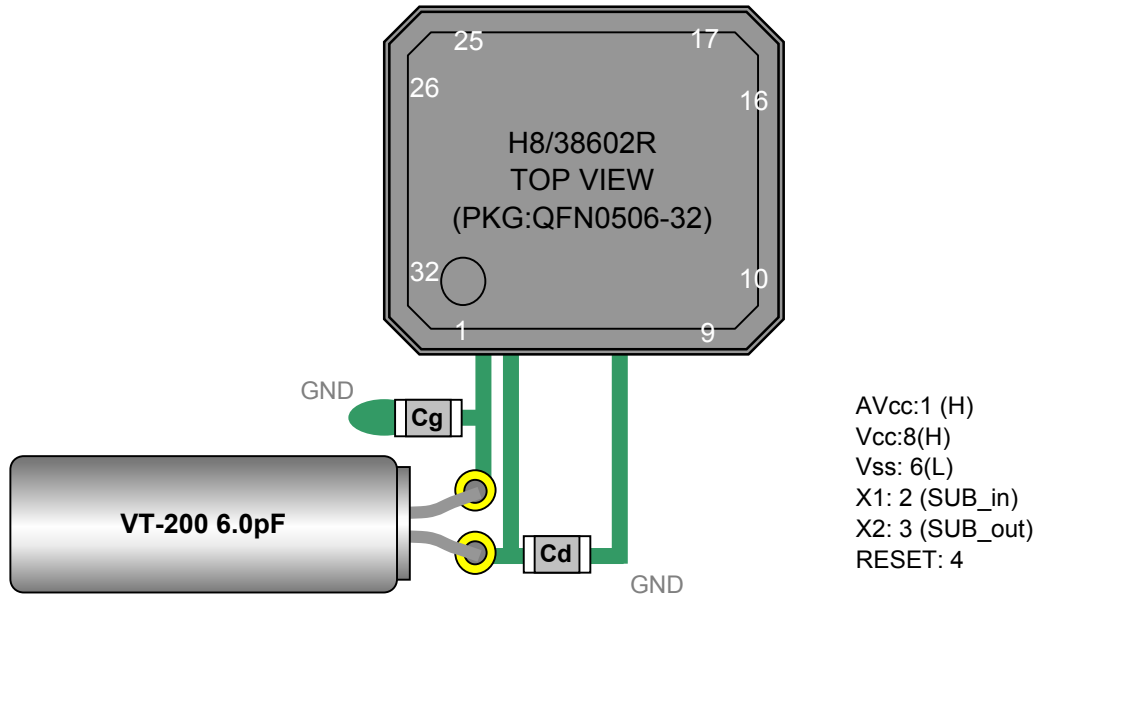

Figure 1 Referential components layout

Notes for Board Design

When using a crystal resonator, place the resonator and its load capacitors as close as possible to SUB_in and SUB_out pins.
 Other signal lines should be routed away from the resonator circuit to prevent induction from interfering with correct oscillation (see figure 2).

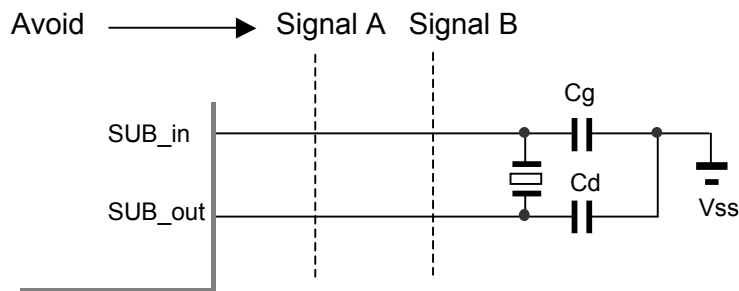

Figure 2 Example of Incorrect Board Design

Evaluation of Subsystem Clock Oscillation Circuit

[HD64338602R-32P] LQFP(6x5) 0.5mm pitch
 Measurement conditions :3.0V



[Evaluation Sample : VT-200 6.0pF at 25°C]

SAMPLE	No.	CL(pF)	Fo(Hz)	fr(Hz)	R1(kohm)	Co(pF)	C1(fF)	Q(k)
VT-200 6.0pF	1	6	32768.18	32762.98	28.7	0.91	2.193	77.2
	2	6	32768.18	32763.04	27.8	0.89	2.161	80.9
	3	6	32768.19	32763.00	27.2	0.90	2.187	81.7

[IC Test Data : IC samples Rd=0 ohm,Cg=2 to 6pF,Cd=3 to 6pF at 25°C]

RESET	IC samples	Fosc(Hz)	df / f(x10 ⁶)	DL(x10 ⁶ W)	-RL (kohm)	Vstart(V)	Ts(sec)
RESET_L	TYP	32768.163	-0.53	0.02	1337	1.54	0.62
	HH	32768.324	4.39	0.02	1337	1.46	0.55
	HL	32768.280	3.04	0.02	1337	1.46	0.52
	LH	32768.440	7.93	0.02	1337	1.33	0.60
	LL	32768.330	4.57	0.02	1337	1.45	0.55
RESET_H	TYP	32768.182	0.05	0.06	367	1.53	0.83
	HH	32768.228	1.46	0.06	397	1.42	0.77
	HL	32768.190	0.30	0.06	367	1.47	0.85
	LH	32768.283	3.14	0.06	397	1.31	0.83
	LL	32768.234	1.64	0.06	397	1.37	0.95

Remark (see figure 3)

$$F_o = f_r \times \{ C_1 / (2 \times (C_o + C_L) + 1) \} \text{ (Hz)}$$

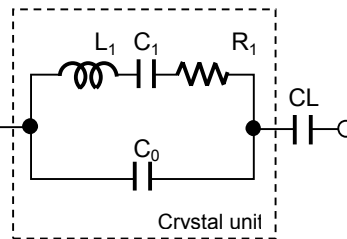

Fo : Load resonance frequency
 fr : Resonance frequency
 R1 : Motional resistance
 C1 : Motional capacitance
 Co : Shunt capacitance
 CL : Load Capacitance

Figure 3 Equivalent circuit of crystal unit, and CL

Remark (see figure 4)

Approximate formula of the load capacitance of the circuit CL.

$$C_L = C_g \times C_d / (C_g + C_d) + C_s \text{ (pF)}$$

Where Cs(=2 to 4pF) Stands for stray capacitance of the circuit.

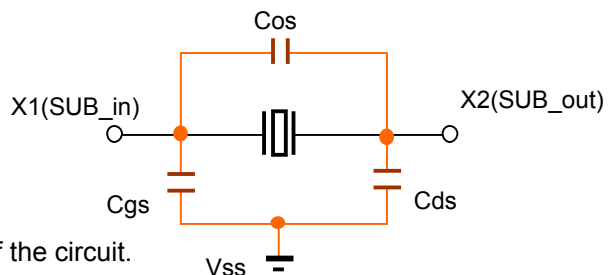

Cos : X1_X2 Stray capacitance
 Cgs : X1_Vss Stray capacitance
 Cds : X2_Vss Stray capacitance

Figure 4 Stray capacitance Cos,Cgs,Cds of the circuit

Resonator circuit constants will differ depending on the resonator element, stray capacitance in its interconnecting circuit, and other factors. Suitable constants should be determined in consultation with the resonator element manufacturer.