

Evaluation of Subsystem Clock Oscillation Circuit

[uPD78F0533GB-8EU] LQFP(10x10) 0.5mm pitch

Measurement conditions : 5.0V , 3.3V

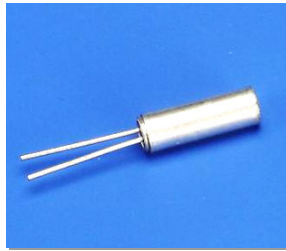

Model	:VT-200
Frequency	:Fo=32.768kHz
Frequency tolerance	:dF/Fo= +/-20x10 ⁶
Load capacitance	:CL=12.5pF
Equivalent series resistance	:R1=50kohm max
Max. drive level	:DL=x10 ⁻⁶ W max
Level of drivel	:DL=0.1x10 ⁻⁶ W typ

FEATURES

- 1.Compact tubular package
- 2.Photolithographic process
- 3.Excellent shock resistance and environmental characteristics.
- 4.Real time clocks, Timers, Portable applications

DIMENSIONS(VT-200)

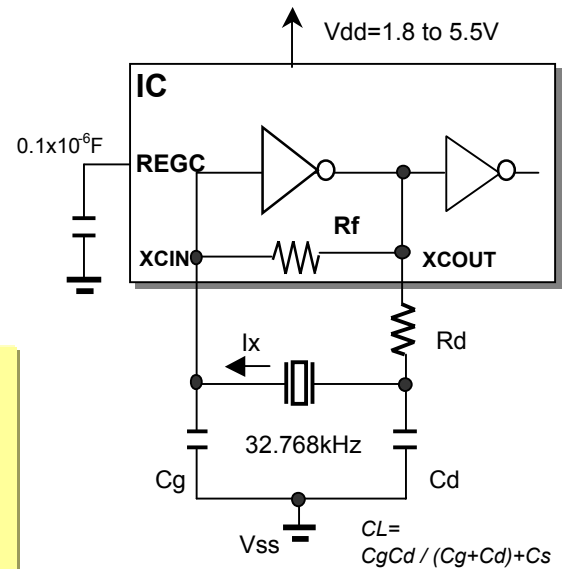
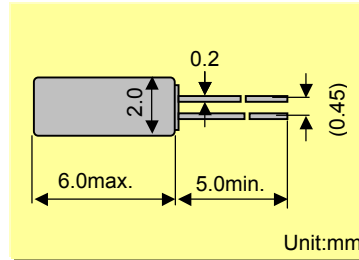

Remark) Ix : current through crystal

MODEL:VT-200 12.5pF with uPD78F0533GB at 25°C

Key specifications	Vdd=3.3V	Vdd=5.0V	Remarks
Current control resistance : Rd (k ohm)	100	100	Control drive level & secure phase margin
Capacitance at gate : Cg (pF)	15	18	Optimal capacity in response to CL
Capacitance at drain : Cd (pF)	15	15	(CL = Cd // Cg + stray capacitance)

Circuit characteristics (at 25°C)	Vdd=3.3V	Vdd=5.0V	Remarks
Matching Accuracy : df / f (x10 ⁻⁶)	-1.0	-0.1	Frequency offset volume at specified Vdd
Voltage Fluctuation : +/-df / V (x10 ⁻⁶)	1.2	1.1	Vdd +/-10% (Standard operating voltage range)
Drive Level : DL (x10 ⁻⁶ W)	0.33	0.54	DL=Ix ² Re < 1x10 ⁻⁶ W, Re=R1(1 + Co / CL) ²
Negative resistance : - RL (kohm)	272	362	5 times larger than R _{1MAX}
Oscillation allowance : M (times)	5.4	7.2	Judgemental standard of oscillation stability
Voltage of oscillation start : Vstart (V)	1.53	1.53	
Voltage of oscillation stop : Vstop (V)	1.49	1.49	
Oscillation start up time : Ts (sec)	1.07	0.87	Time to reach 90% of output level

Temperature characteristics of circuit		Vdd=3.3V	Vdd=5.0V	Remarks
at -40°C	Variation : df / T (x10 ⁻⁶)	-140	-139	Typ.Tp=25°C (K = -3.5x10 ⁻⁸ / °C ²)
at +85°C	Variation : df / T (x10 ⁻⁶)	-129	-130	Typ.Tp=25°C (K = -3.5x10 ⁻⁸ / °C ²)

The above mentioned value is only for your reference. The value is for the arbitrary samples and does not guarantee the product's characteristics. Please review and check above parameters at customer's end.

Seiko Instruments USA Inc.

2990, West Lomita Blvd., Torrance, CA 90505, U.S.A
 Telephone : +1 310-517-7771 Facsimile : +1 310-517-7792
 Email : crystals@siu-la.com

Seiko Instruments GmbH

Siemensstrasse 9, D-63263 Neu-Isenburg, Germany
 Telephone : +49-6102-297-0 Facsimile : +49-6102-297-320
 Email : info@seiko-instruments.de

Seiko Instruments Inc.

1-8, Nakase, Mihama-ku, Chiba-shi, Chiba 261-8507, Japan
 Facsimile : +81-43-211-8030
 E-mail : component@sii.co.jp



We value the "takumi" spirit.

Seiko Instruments Inc.
 Phone: +81-43-211-1207(Direct)

Evaluation of Subsystem Clock Oscillation Circuit

[uPD78F0533GB-8EU] LQFP(10x10) 0.5mm pitch

Measurement conditions : 5.0V , 3.3V



Test Data

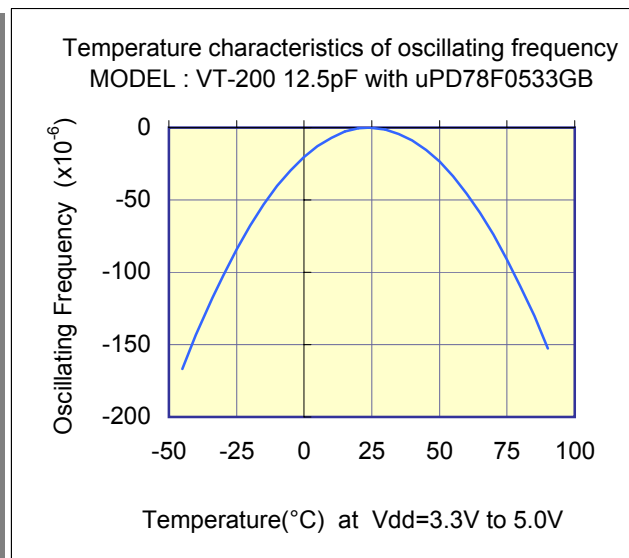
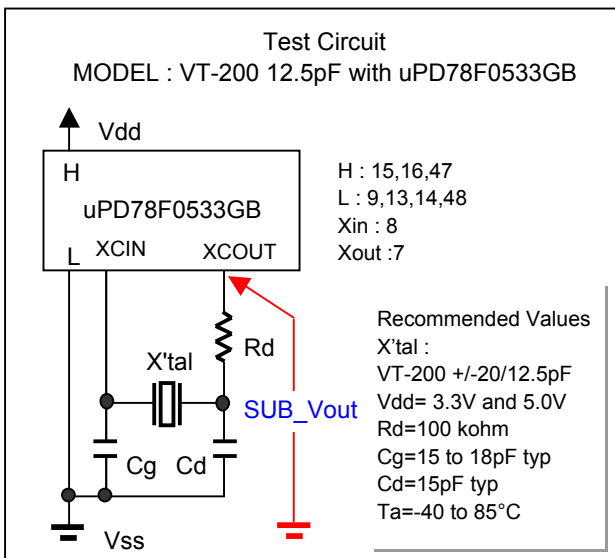
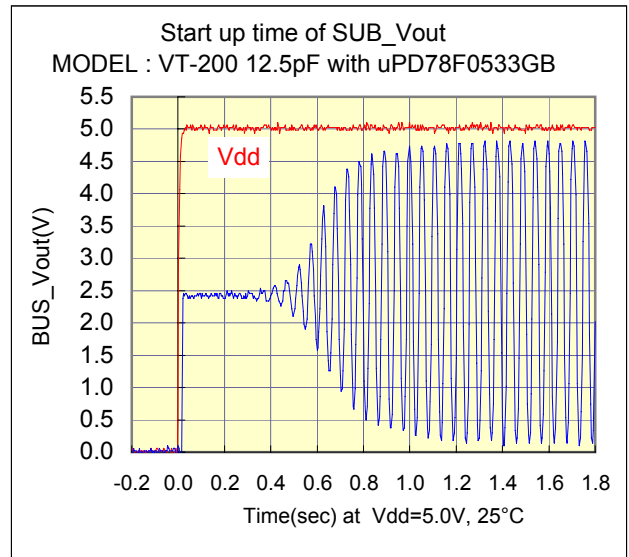
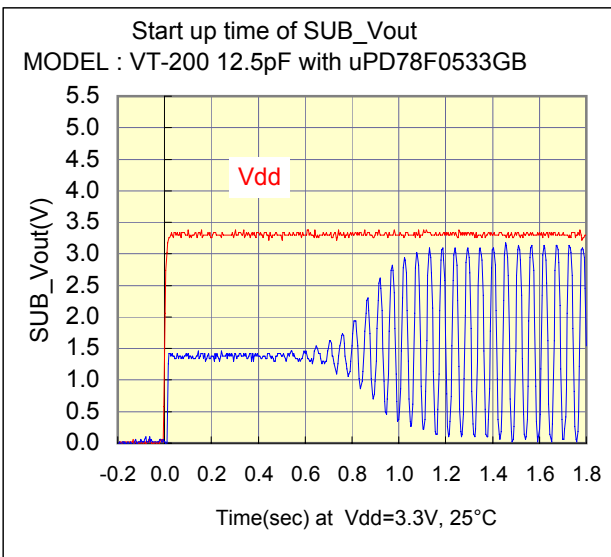
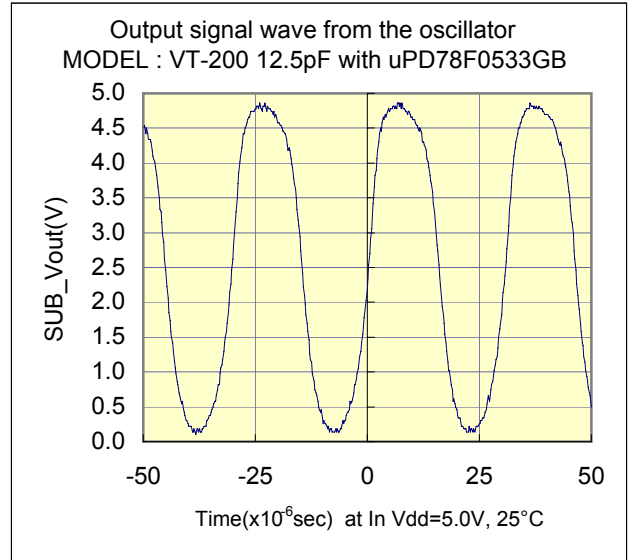
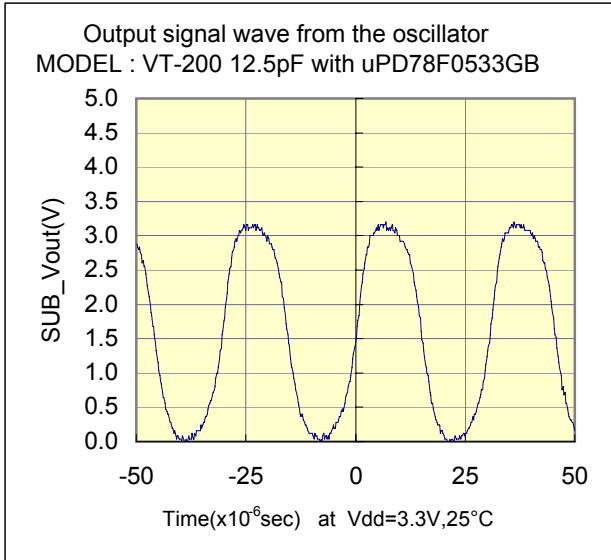

Evaluation of Subsystem Clock Oscillation Circuit

[uPD78F0533GB-8EU] LQFP(10x10) 0.5mm pitch

Measurement conditions : 5.0V , 3.3V



Test Data : Temperature characteristics

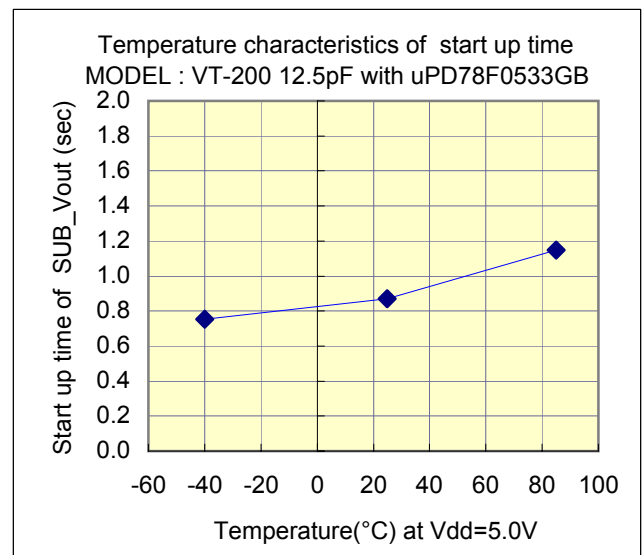
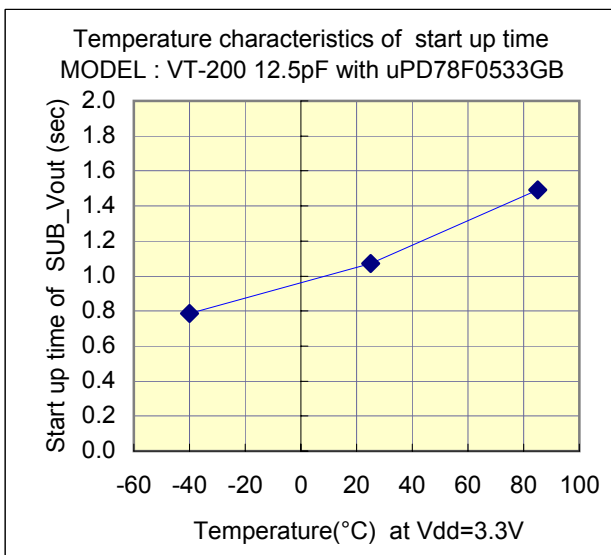
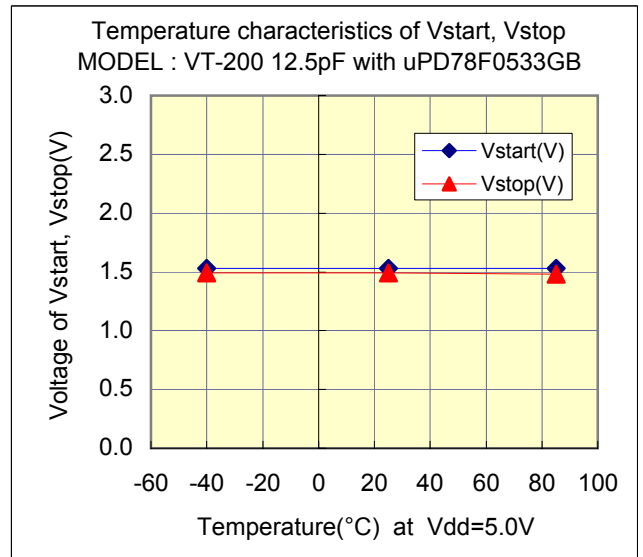
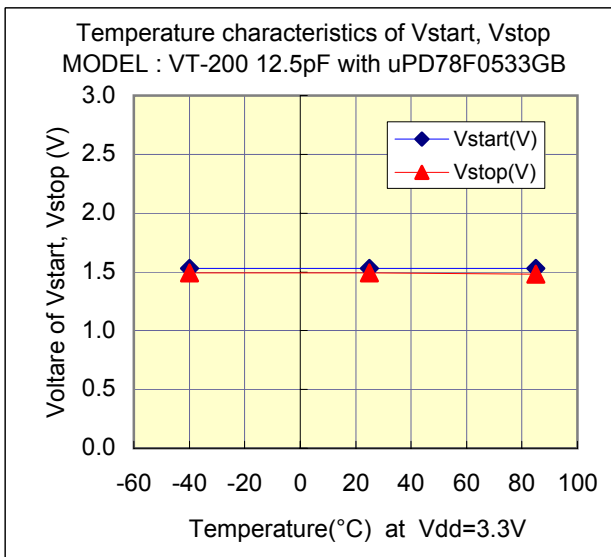
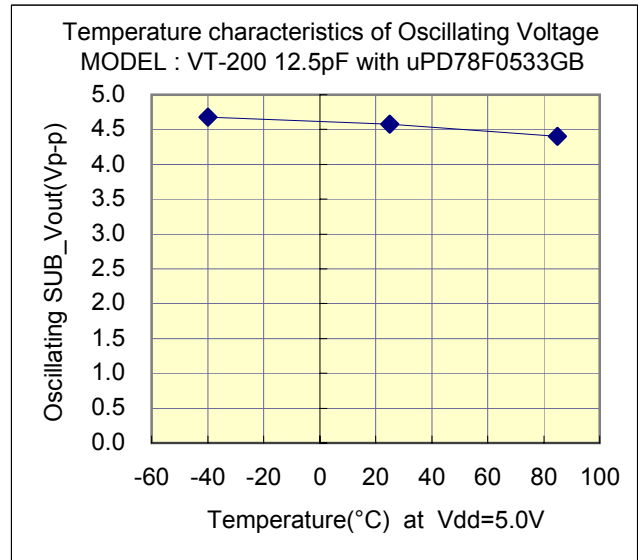
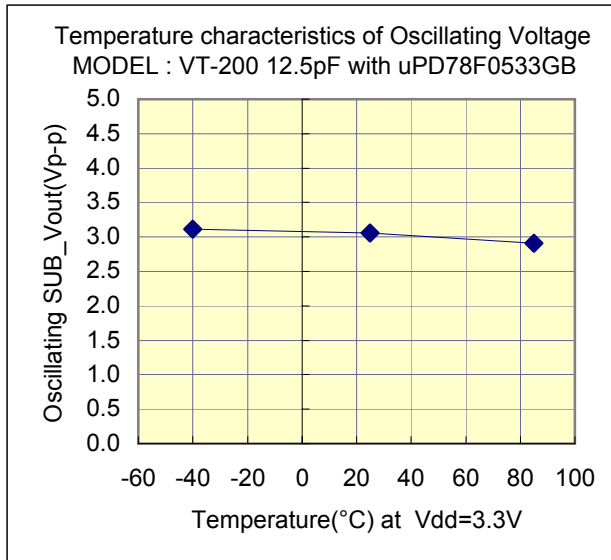

Evaluation of Subsystem Clock Oscillation Circuit

[μ PD78F0533GB-8EU] LQFP(10x10) 0.5mm pitch

Measurement conditions : 5.0V , 3.3V



Referential components layout(see Figure 1)

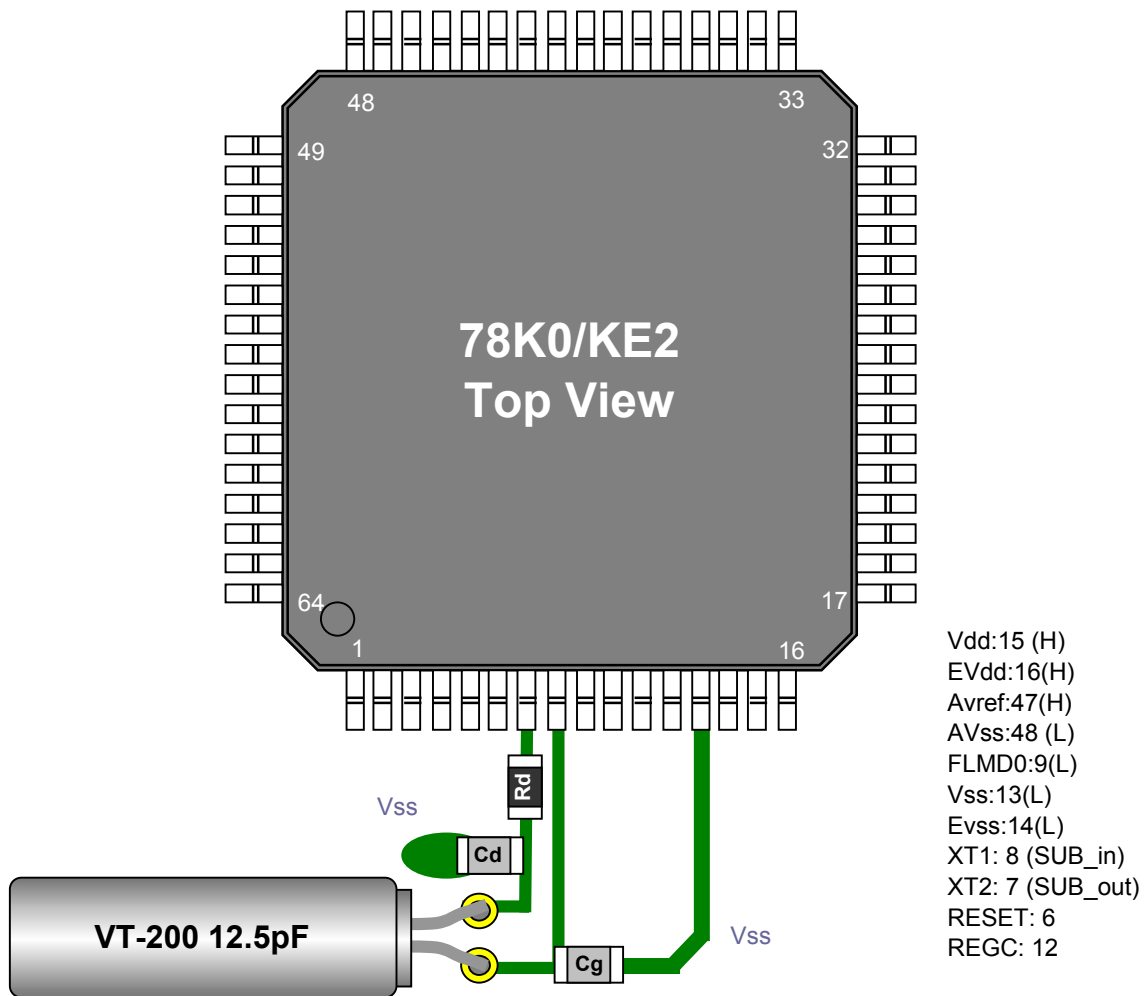

Figure 1 Referential components layout

Notes for Board Design

When using a crystal resonator, place the resonator and its load capacitors as close as possible to SUB_in and SUB_out pins.

Other signal lines should be routed away from the resonator circuit to prevent induction from interfering with correct oscillation (see figure 2).

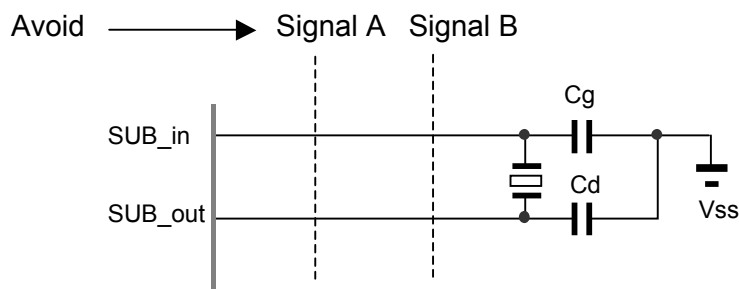

Figure 2 Example of Incorrect Board Design

Remark When using the subsystem clock, insert resistors Rd in series on the SUB_out side.



Evaluation of Subsystem Clock Oscillation Circuit

[uPD78F0533GB-8EU] LQFP(10x10) 0.5mm pitch

Measurement conditions : 5.0V , 3.3V



[Evaluation Sample : VT-200 12.5pF at 25°C]

SAMPLE	No.	CL(pF)	Fo(Hz)	fr(Hz)	R1(kohm)	Co(pF)	C1(fF)	Q(k)
VT-200 12.5pF	1	12.5	32768.11	32765.28	27.4	0.91	2.319	76.5
	2	12.5	32768.09	32765.24	26.9	0.89	2.333	77.4
	3	12.5	32768.34	32765.45	29.9	0.93	2.368	68.6

[IC Test Data : IC Sample Rd=100 kohm,Cg=18pF,Cd=15pF at 25°C]

Vdd(V)	IC Sample	Fosc(Hz)	df / f(x10 ⁻⁶)	DL(x10 ⁻⁶ W)	-RL (kohm)	Vstart(V)	Ts(sec)
5.0	CC	32768.11	-0.09	0.54	361.53	1.53	0.87
	LL	32768.15	1.13	0.44	391.53	1.51	0.87
	LH	32768.10	-0.40	0.53	361.53	1.55	0.86
	HL	32768.12	0.21	0.49	391.53	1.51	0.89
	HH	32768.07	-1.31	0.59	331.53	1.50	0.86

[IC Test Data : IC Sample Rd=100 kohm,Cg=15pF,Cd=15pF at 25°C]

Vdd(V)	IC Sample	Fosc(Hz)	df / f(x10 ⁻⁶)	DL(x10 ⁻⁶ W)	-RL (kohm)	Vstart(V)	Ts(sec)
3.3	CC	32768.08	-1.01	0.33	271.53	1.53	1.07
	LL	32768.09	-0.76	0.28	301.53	1.50	1.00
	LH	32768.04	-2.23	0.33	251.53	1.54	1.27
	HL	32768.08	-1.10	0.29	251.53	1.51	1.02
	HH	32768.03	-2.53	0.34	251.53	1.50	1.21

Remark (see figure 3)

$$Fo = fr \times \{ C1 / (2 \times (Co + CL) + 1) \} \text{ (Hz)}$$

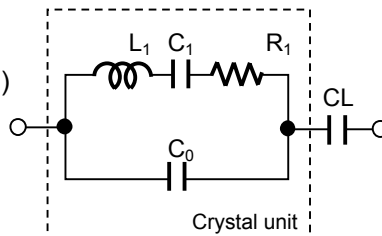

Fo : Load resonance frequency
 fr : Resonance frequency
 R1 : Motional resistance
 C1 : Motional capacitance
 Co : Shunt capacitance
 CL : Load Capacitance

Figure 3 Equivalent circuit of crystal unit, and CL

Remark (see figure 4)

Approximate formula of the load capacitance of the circuit CL.

$$CL = Cg \times Cd / (Cg + Cd) + Cs \text{ (pF)}$$

Where Cs(=2 to 4pF) Stands for stray capacitance of the circuit.

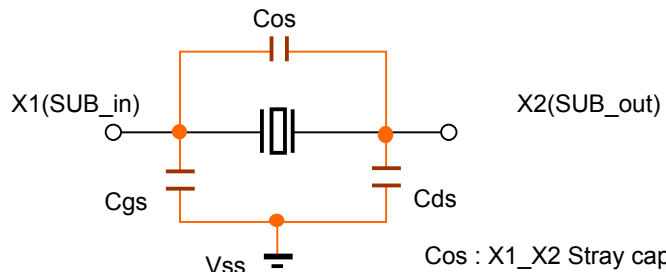

Cos : X1_X2 Stray capacitance
 Cgs : X1_Vss Stray capacitance
 Cds : X2_Vss Stray capacitance

Figure 4 Stray capacitance Cos,Cgs,Cds of the circuit

Resonator circuit constants will differ depending on the resonator element, stray capacitance in its interconnecting circuit, and other factors. Suitable constants should be determined in consultation with the resonator element manufacturer.

