

Evaluation of Subsystem Clock Oscillation Circuit

[M30260F6T-48P] LQFP(7x7) 0.5mm pitch

Measurement conditions :3.3V



Model :VT-200
 Frequency :Fo=32.768kHz
 Frequency tolerance :dF/Fo= +/-20x10⁶
 Load capacitance :CL=12.5pF
 Equivalent series resistance :R1=50kohm max
 Max. drive level :DL=1x10⁶W max
 Level of drive :DL=0.1x10⁶W typ

FEATURES

- 1.Compact tubular package
- 2.Photolithographic process
- 3.Excellent shock resistance and environmental characteristics.
- 4.Real time clocks, Timers, Portable applications

DIMENSIONS(VT-200)

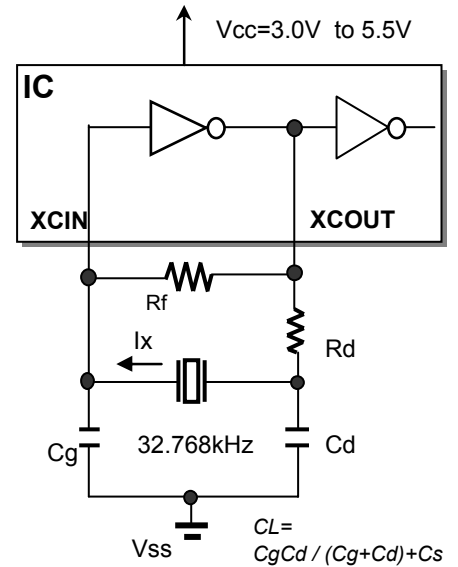
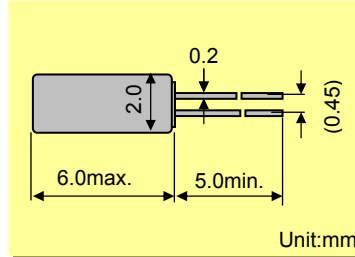

Remark) Ix : current through crystal

MODEL:VT-200 12.5pF with M30260F6T at 25°C

Key specifications	Low	High	Remarks
Negative feedback resistance : Rf (M ohm)	open	open	
Current control resistance : Rd (k ohm)	0	0	Control drive level & secure phase margin
Capacitance at gate : Cg (pF)	18	27	Optimal capacity in response to CL
Capacitance at drain : Cd (pF)	18	27	(CL = Cd // Cg + stray capacitance)

Circuit characteristics (at 25°C)	Low	High	Remarks
Matching Accuracy : df / f (x10 ⁻⁶)	-1.2	5.0	Frequency offset volume at specified Vdd
Voltage Fluctuation : +/-df / V (x10 ⁻⁶)	0.0	1.0	Vdd +/-10% (Standard operating voltage range)
Drive Level : DL (x10 ⁻⁶ W)	0.15	0.12	DL=Ix ² Re < 1x10 ⁶ W, Re=R1(1 + Co / CL) ²
Negative resistance : - RL (kohm)	274	1134	5 times larger than R _{1MAX}
Oscillation allowance : M (times)	5.5	22.7	Judgemental standard of oscillation stability
Voltage of oscillation start : Vstrat (V)	1.73	1.71	
Voltage of oscillation stop : Vstop (V)	1.52	1.52	
Oscillation start up time : Ts (sec)	0.00	0.32	Time to reach 90% of output level

Temperature characteristics of circuit		Low	High	Remarks
at -40°C	Variation : df / T (x10 ⁻⁶)	-139	-139	Typ.Tp=25°C (K = -3.5x10 ⁻⁸ / °C ²)
at +85°C	Variation : df / T (x10 ⁻⁶)	-134	-133	Typ.Tp=25°C (K = -3.5x10 ⁻⁸ / °C ²)

The above mentioned value is only for your reference. The value is for the arbitrary samples and does not guarantee the product's characteristics. Please review and check above parameters at customer's end.

Seiko Instruments USA Inc.

2990,West Lomita Blvd., Torrance, CA 90505, U.S.A
 Telephone :+1 310-517-7771 Facsimile :+1 310-517-7792
 Email :crystals@siu-la.com

Seiko Instruments GmbH

Siemensstrasse 9,D-63263 Neu-Isenburg,Germany
 Telephone :+49-6102-297-0 Facsimile :+49-6102-297-320
 Email :info@seiko-instruments.de

Seiko Instruments Inc.

1-8,Nakase,Mihama-ku,Chiba-shi,Chiba 261-8507,Japan
 Facsimile :+81-43-211-8030
 E-mail :component@sii.co.jp

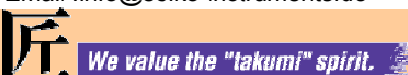

Seiko Instruments Inc.
 Phone:+81-43-211-1207(Direct)

Evaluation of Subsystem Clock Oscillation Circuit

[M30260F6T-48P] LQFP(7x7) 0.5mm pitch

Measurement conditions :3.3V



Test Data at 25°C

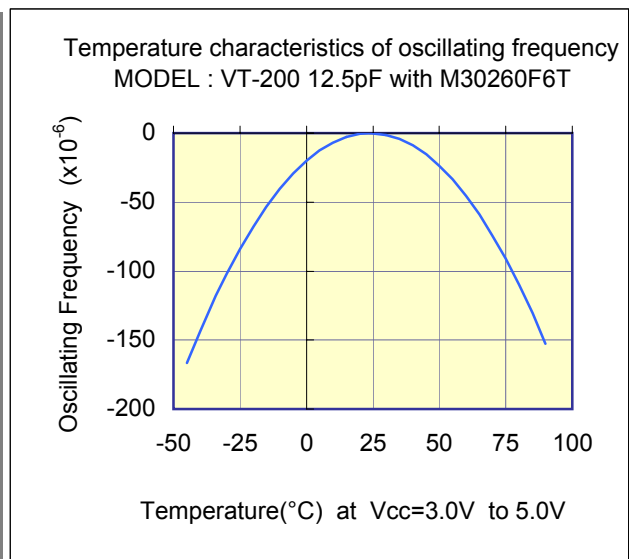
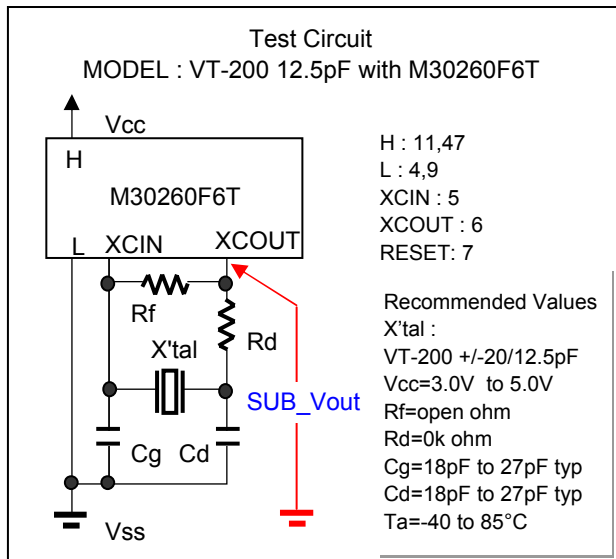
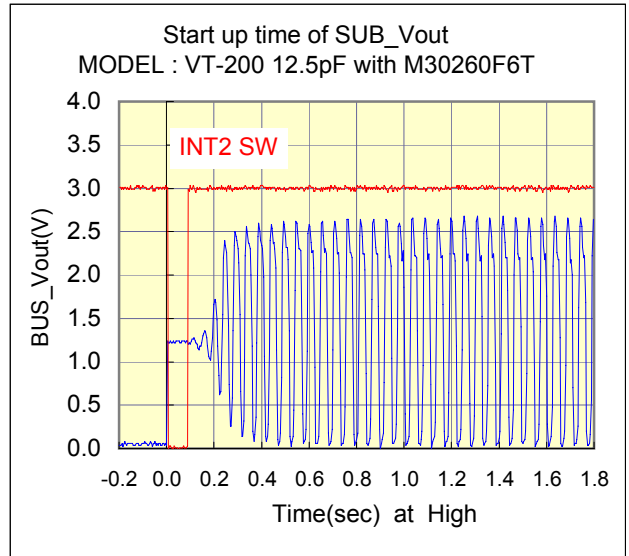
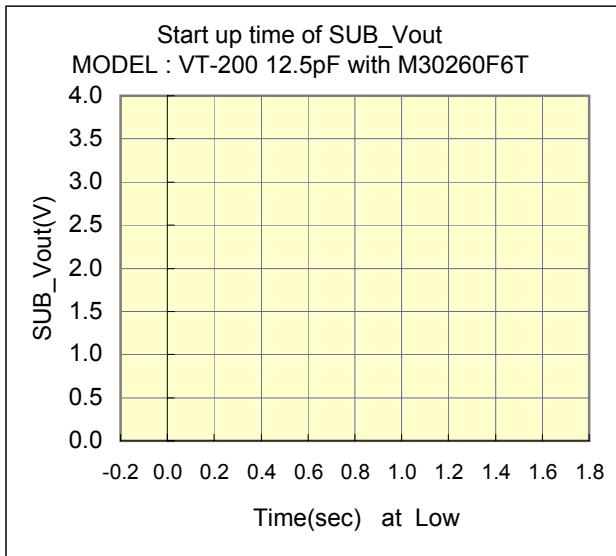
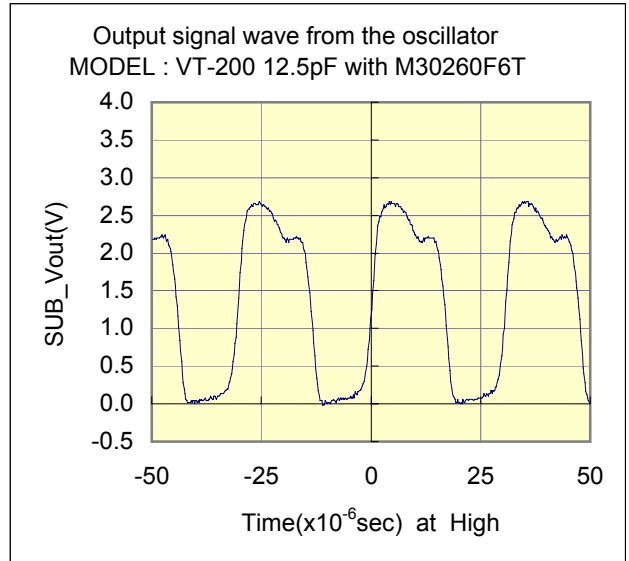
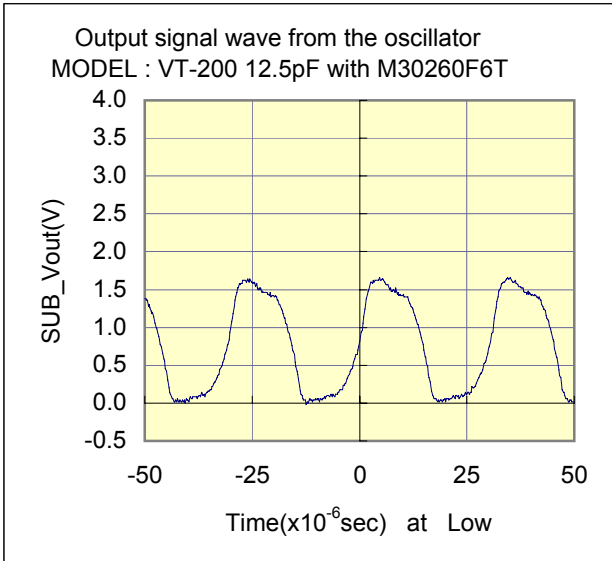

Evaluation of Subsystem Clock Oscillation Circuit

[M30260F6T-48P] LQFP(7x7) 0.5mm pitch

Measurement conditions :3.3V



Test Data : Temperature characteristics

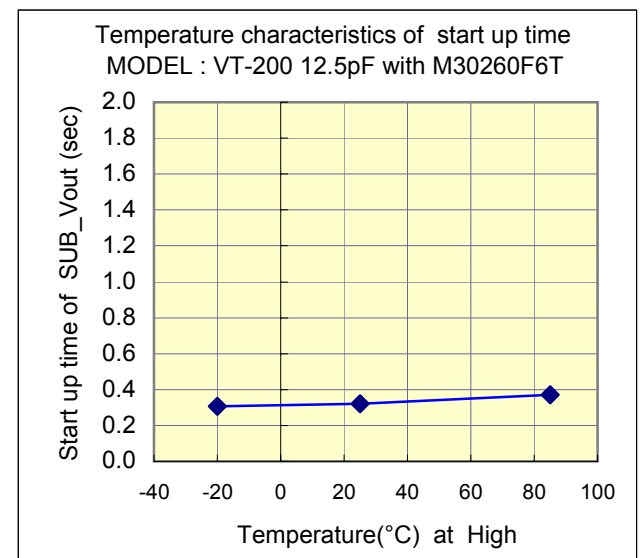
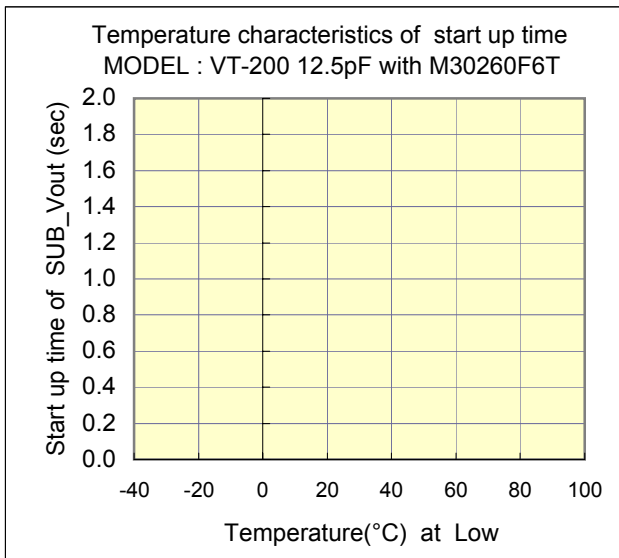
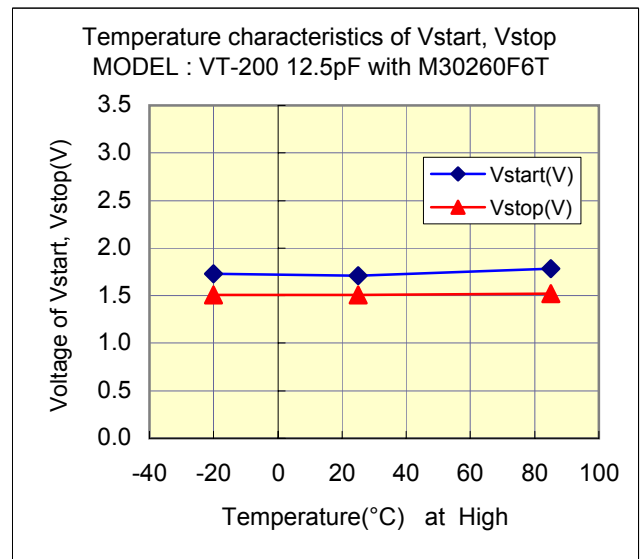
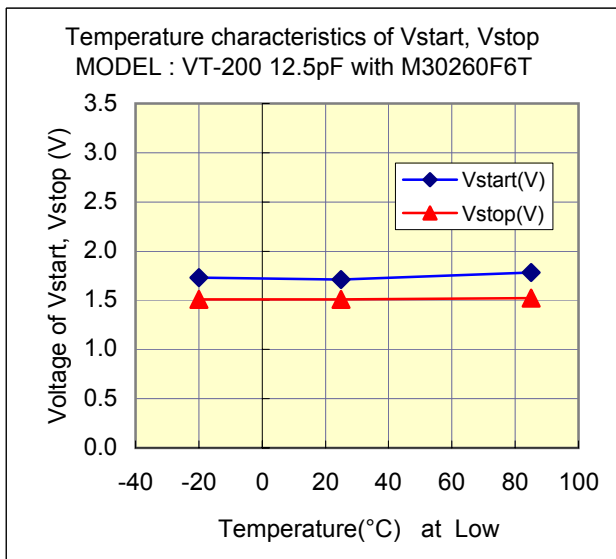
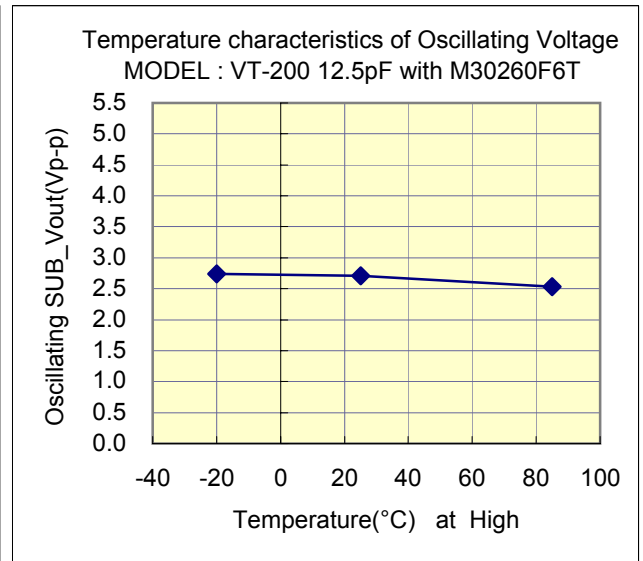
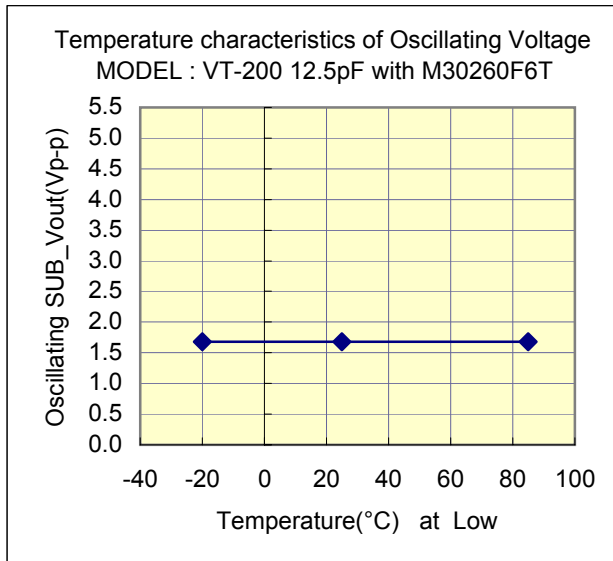

Evaluation of Subsystem Clock Oscillation Circuit

[M30260F6T-48P] LQFP(7x7) 0.5mm pitch

Measurement conditions :3.3V



Referential components layout(see Figure 1)

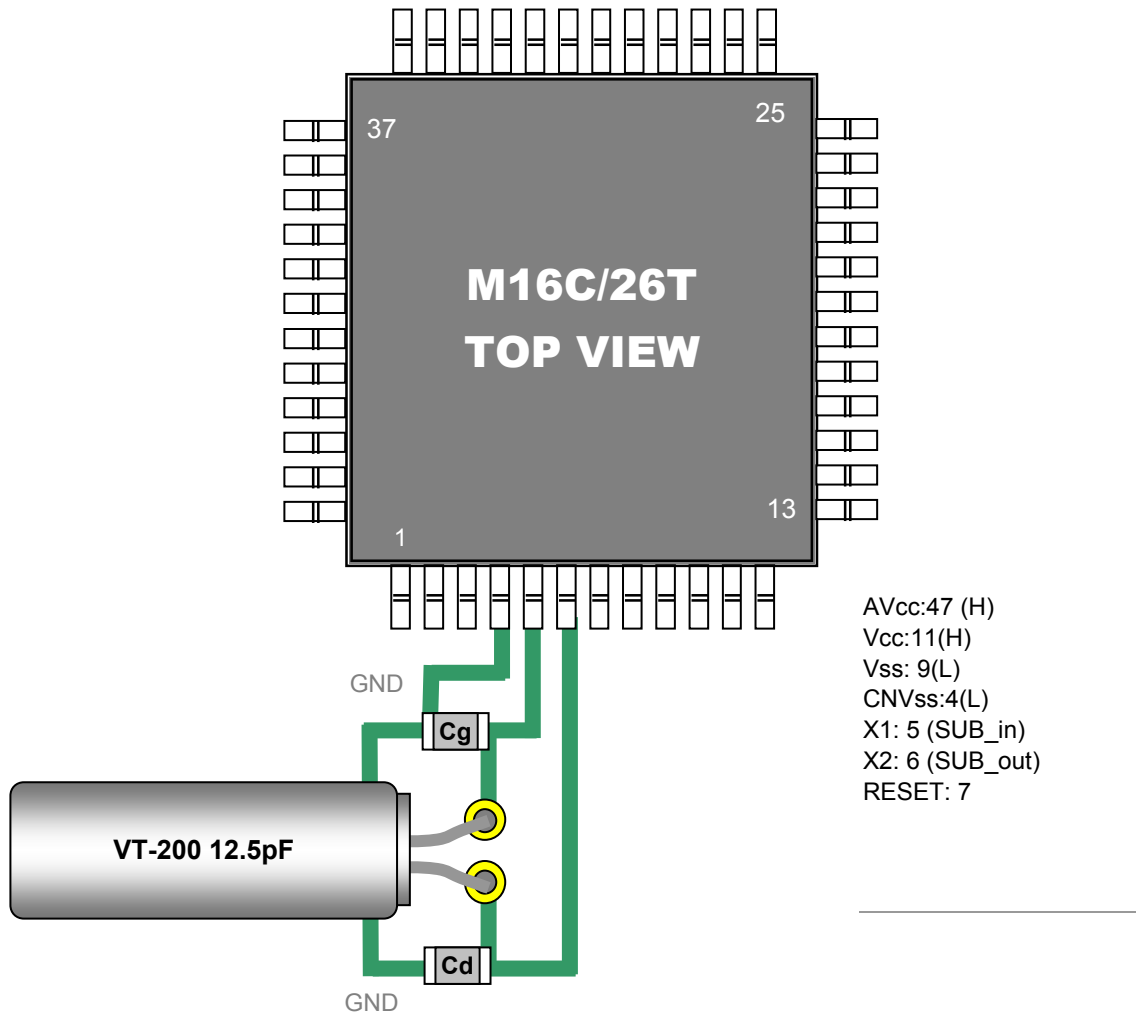

Figure 1 Referential components layout

Notes for Board Design

When using a crystal resonator, place the resonator and its load capacitors as close as possible to SUB_in and SUB_out pins.

Other signal lines should be routed away from the resonator circuit to prevent induction from interfering with correct oscillation (see figure 2).

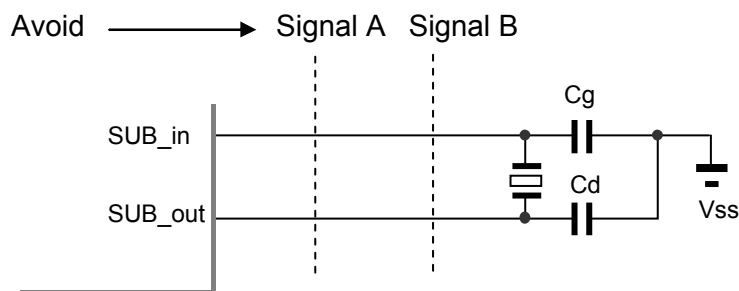

Figure 2 Example of Incorrect Board Design

Remark When using the subsystem clock, insert resistors Rd in series on the SUB_out side.

Evaluation of Subsystem Clock Oscillation Circuit



[M30260F6T-48P] LQFP(7x7) 0.5mm pitch

Measurement conditions :3.3V

[Evaluation Sample : VT-200 12.5pF at 25°C]

SAMPLE	No.	CL(pF)	Fo(Hz)	fr(Hz)	R1(kohm)	Co(pF)	C1(fF)	Q(k)
VT-200 12.5pF	1	12.5	32768.11	32765.28	27.4	0.91	2.319	76.5
	2	12.5	32768.09	32765.24	26.9	0.89	2.333	77.4
	3	12.5	32768.34	32765.45	29.9	0.93	2.368	68.6

[IC Test Data : IC samples Rd=0k ohm,Cg=Cd=18pF to 27pF at 25°C]

Power mode	IC samples	Fosc(Hz)	df / f(x10 ⁻⁶)	DL(x10 ⁻⁶ W)	-RL (kohm)	Vstart(V)	Ts(sec)
High	TYP	32768.505	5.05	0.12	1134	1.71	0.32
	HH	32768.439	3.05	0.11	1034	1.71	0.31
	LL	32769.081	22.65	0.17	1134	1.70	0.34
Low	TYP	32768.300	-1.20	0.15	274	1.73	-
	HH	32768.330	-0.28	0.14	274	1.71	-
	LL	32768.320	-0.59	0.17	274	1.75	-

Remark (see figure 3)

$$F_o = f_r \times \{ C_1 / (2 \times (C_o + C_L) + 1) \} \text{ (Hz)}$$

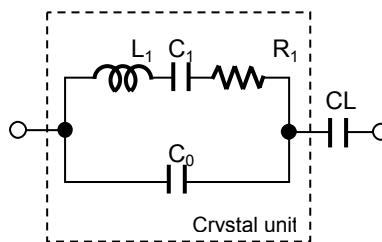

- Fo : Load resonance frequency
- fr : Resonance frequency
- R1 : Motional resistance
- C1 : Motional capacitance
- Co : Shunt capacitance
- CL : Load Capacitance

Figure 3 Equivalent circuit of crystal unit, and CL

Remark (see figure 4)

Approximate formula of the load capacitance of the circuit CL.

$$C_L = C_g \times C_d / (C_g + C_d) + C_s \text{ (pF)}$$

Where Cs(=2 to 4pF) Stands for stray capacitance of the circuit.

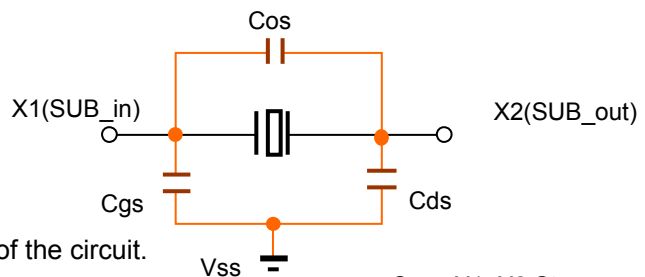

- Cos : X1_X2 Stray capacitance
- Cgs : X1_Vss Stray capacitance
- Cds : X2_Vss Stray capacitance

Figure 4 Stray capacitance Cos,Cgs,Cds of the circuit

Resonator circuit constants will differ depending on the resonator element, stray capacitance in its interconnecting circuit, and other factors. Suitable constants should be determined in consultation with the resonator element manufacturer.