

# Evaluation of Subsystem Clock Oscillation Circuit

[M3455AGCFP-52P] LQFP(10x10) 0.65mm pitch

Measurement conditions :5.0V,3.0V



Model	:VT-200
Frequency	:Fo=32.768kHz
Frequency tolerance	:dF/Fo= +/-20x10 <sup>6</sup>
Load capacitance	:CL=6.0pF
Equivalent series resistance	:R1=50kohm max
Max. drive level	:DL=1x10 <sup>6</sup> W max
Level of drive	:DL=0.1x10 <sup>6</sup> W typ

## FEATURES

- 1.Compact tubular package
- 2.Photolithographic process
- 3.Excellent shock resistance and environmental characteristics.
- 4.Real time clocks, Timers, Portable applications

## DIMENSIONS(VT-200)

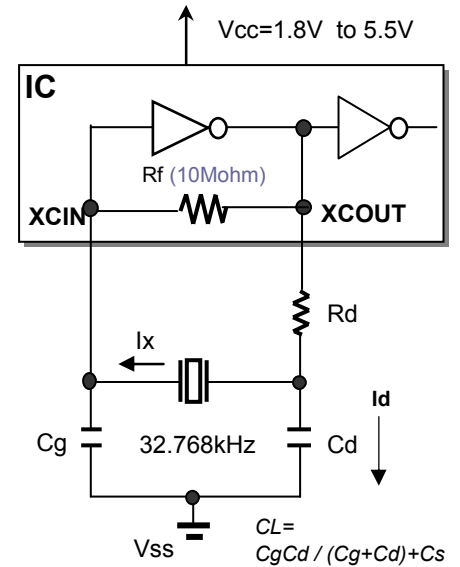
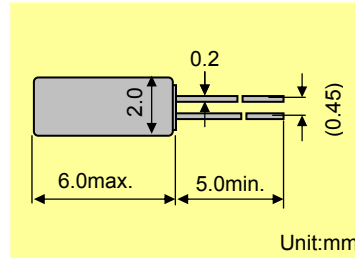

Remark)  $I_x$  : current through crystal

MODEL:VT-200 6.0pF with M3455AGCFP at 25°C

Key specifications	Vcc=3.0V	Vcc=5.0V	Remarks
Current control resistance : Rd ( k ohm )	330	330	Control drive level & secure phase margin
Capacitance at gate : Cg ( pF )	8	8	Optimal capacitance in response to CL
Capacitance at drain : Cd ( pF )	7	7	( CL = Cd // Cg + stray capacitance )

Circuit characteristics ( at 25°C )	Vcc=3.0V	Vcc=5.0V	Remarks
Matching Accuracy : $df / f$ ( $\times 10^{-6}$ )	1.0	2.4	Frequency offset volume at specified Vcc
Voltage Fluctuation : $\pm df / V$ ( $\times 10^{-6}$ )	1.3	-0.1	Vcc +/-10% ( Standard operating voltage range )
Drive Level : DL ( $\times 10^{-6}$ W )	0.01	0.01	$DL = I_x^2 R_e < 1 \times 10^{-6}$ W, $R_e = R_1 ( 1 + C_o / CL )^2$
Negative resistance : $  -RL  $ ( kohm )	2037	857	5 times larger than $R_{1MAX}$
Oscillation allowance : M ( times )	40.7	17.1	Judgemental standard of oscillation stability
consumption current : Id (nA)	825	826	Cd charge current, $I_d = \omega C_d \cdot V_d$
Voltage of oscillation start : Vstart ( V )	1.05	1.05	
Voltage of oscillation stop : Vstop ( V )	0.95	0.95	
Oscillation start up time : Ts ( sec )	0.30	0.36	Time to reach 90% of output level

Temperature characteristics of circuit		Vcc=3.0V	Vcc=5.0V	Remarks
at -20°C	Variation : $df / T$ ( $\times 10^{-6}$ )	-69	-66	Typ.Tp=25°C ( K = $-3.5 \times 10^{-8} / ^\circ C^2$ )
at +85°C	Variation : $df / T$ ( $\times 10^{-6}$ )	-130	-133	Typ.Tp=25°C ( K = $-3.5 \times 10^{-8} / ^\circ C^2$ )

The above mentioned value is only for your reference. The value is for the arbitrary samples and does not guarantee the product's characteristics. Please review and check above parameters at customer's end.

### Seiko Instruments USA Inc.

2990,West Lomita Blvd., Torrance, CA 90505, U.S.A  
 Telephone :+1 310-517-7771 Facsimile :+1 310-517-7792  
 Email :crystals@siu-la.com

### Seiko Instruments GmbH

Siemensstrasse 9,D-63263 Neu-Isenburg,Germany  
 Telephone :+49-6102-297-0 Facsimile :+49-6102-297-320  
 Email :info@seiko-instruments.de

### Seiko Instruments Inc.

1-8,Nakase,Mihama-ku,Chiba-shi,Chiba 261-8507,Japan  
 Facsimile :+81-43-211-8030  
 E-mail :component@sii.co.jp



We value the "takumi" spirit.

Seiko Instruments Inc.  
 Phone:+81-43-211-1207(Direct)

# Evaluation of Subsystem Clock Oscillation Circuit

[M3455AGCFP-52P] LQFP(10x10) 0.65mm pitch

Measurement conditions :5.0V,3.0V



## Test Data at 25°C

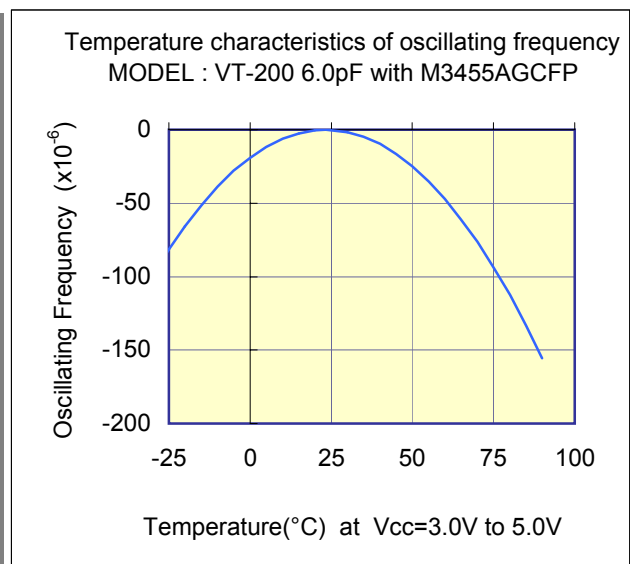
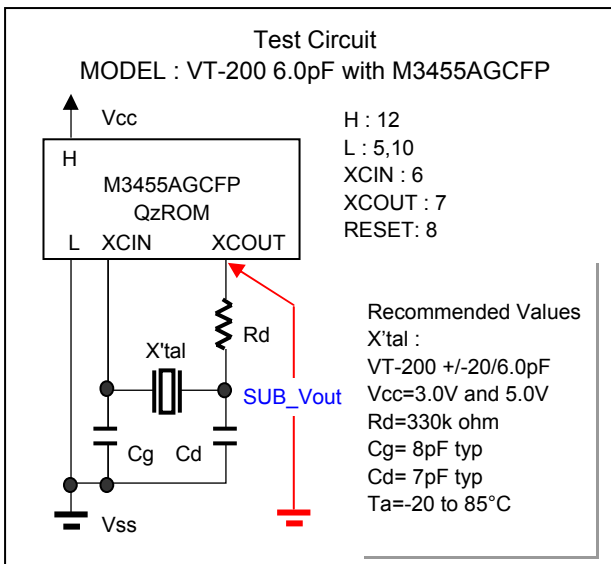
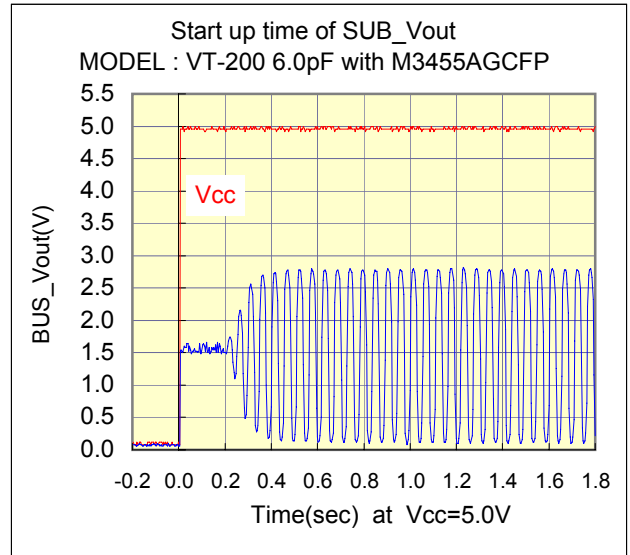
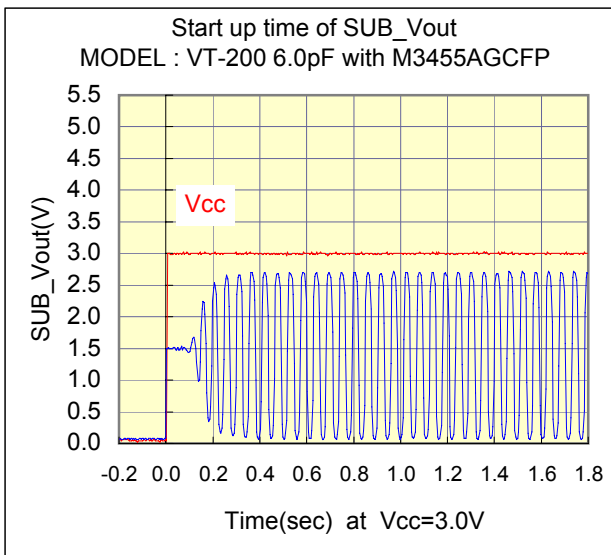
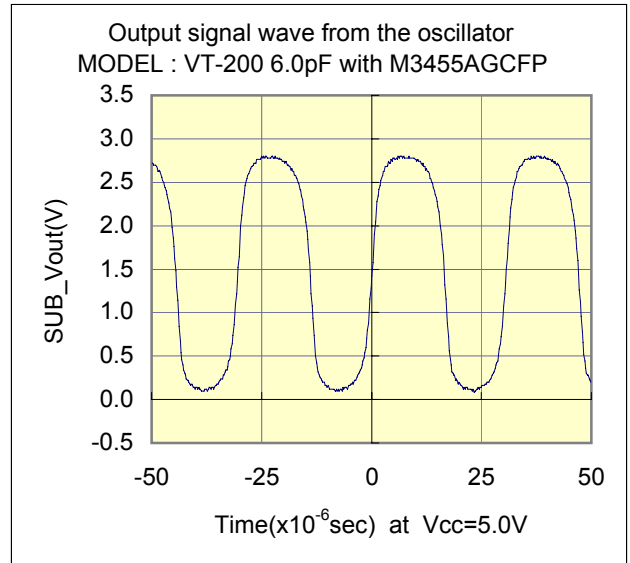
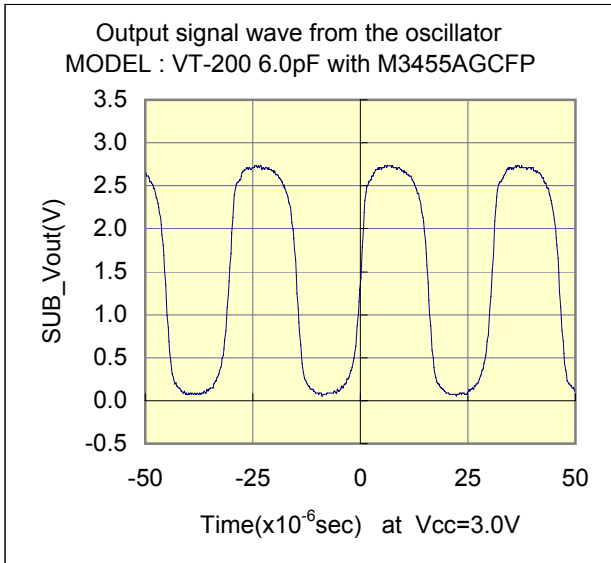

# Evaluation of Subsystem Clock Oscillation Circuit

[M3455AGCFP-52P] LQFP(10x10) 0.65mm pitch

Measurement conditions :5.0V,3.0V



## Test Data : Temperature characteristics

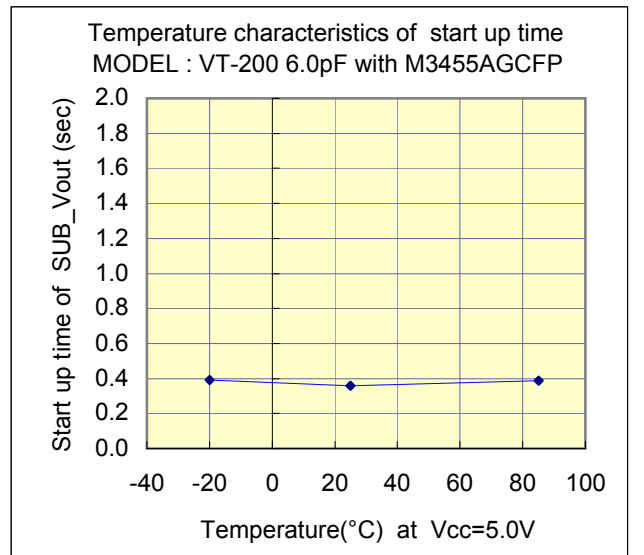
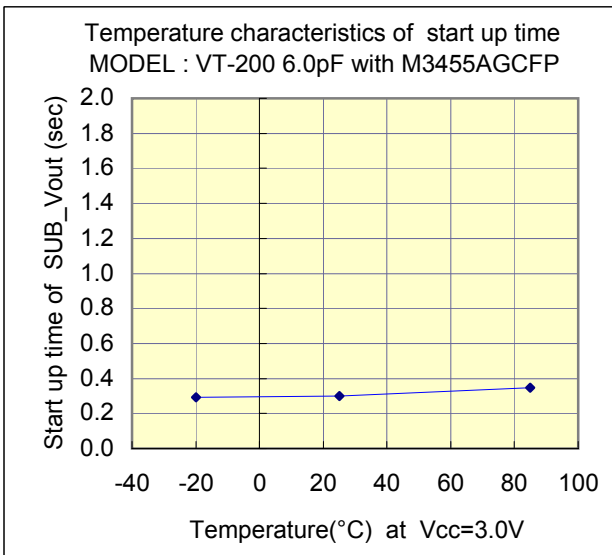
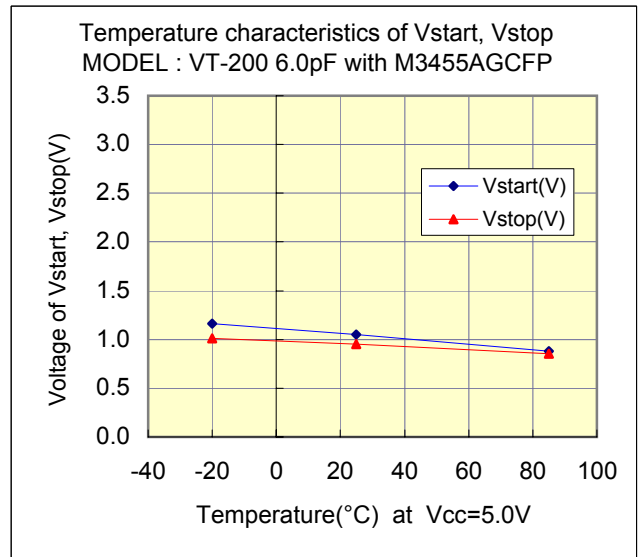
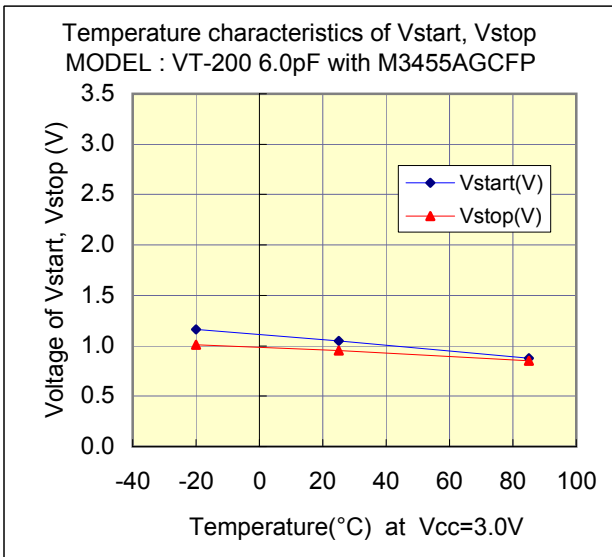
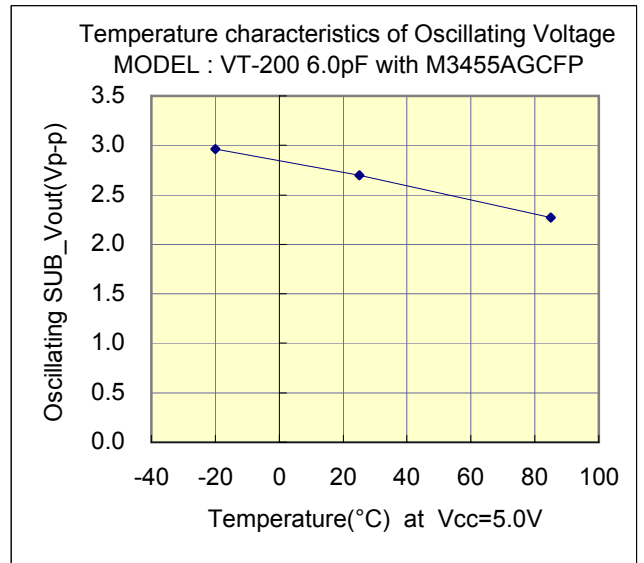
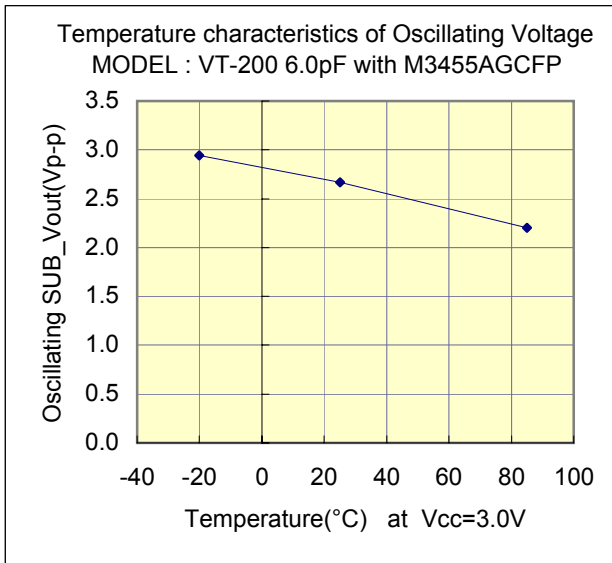

# Evaluation of Subsystem Clock Oscillation Circuit

[M3455AGCFP] LQFP(10x10) 0.65mm pitch

Measurement conditions :5.0V,3.0V



## Referential components layout(see Figure 1)

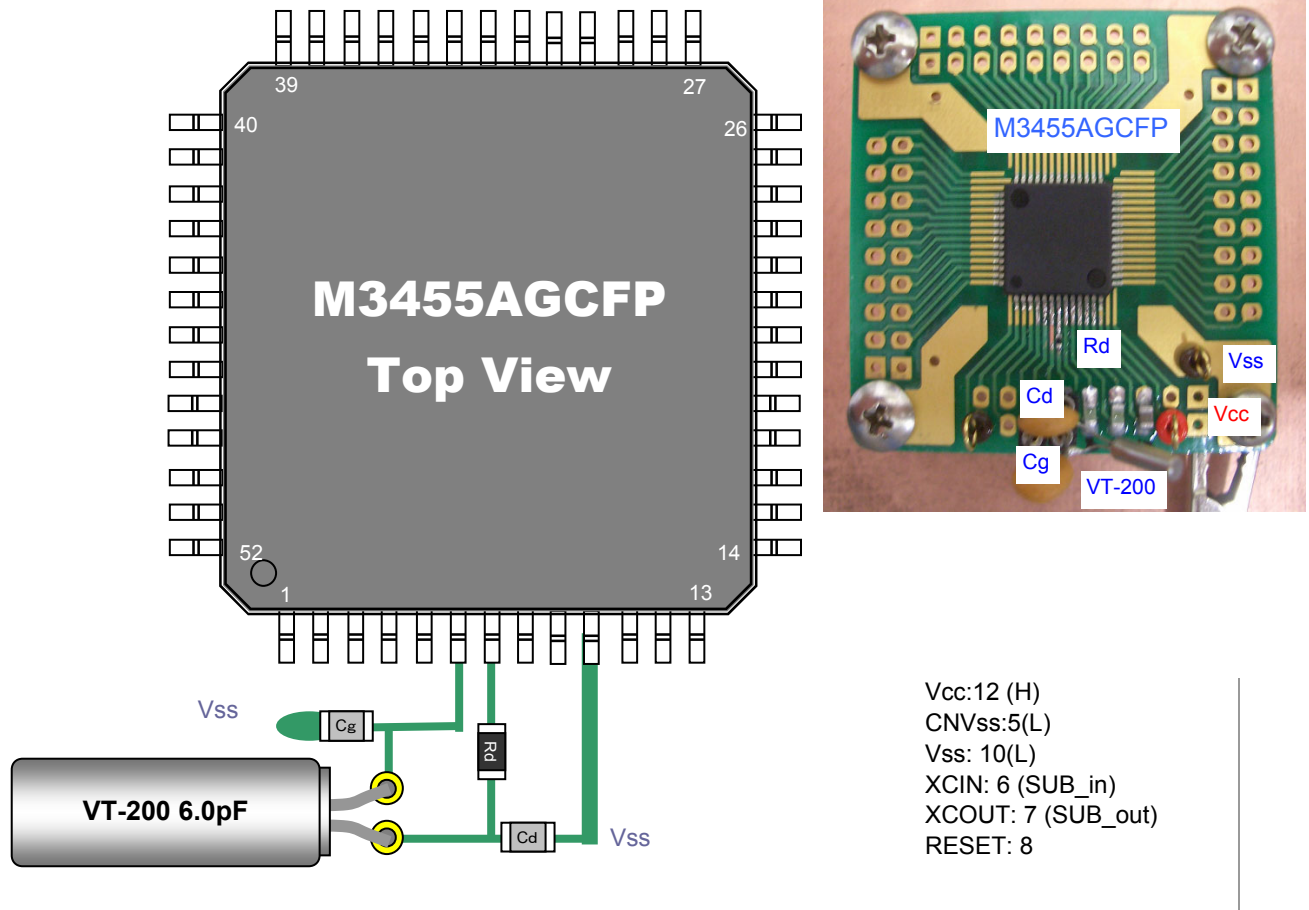

Figure 1 Referential components layout

## Notes for Board Design

When using a crystal resonator, place the resonator and its load capacitors as close as possible to SUB\_in and SUB\_out pins.

Other signal lines should be routed away from the resonator circuit to prevent induction from interfering with correct oscillation (see figure 2).

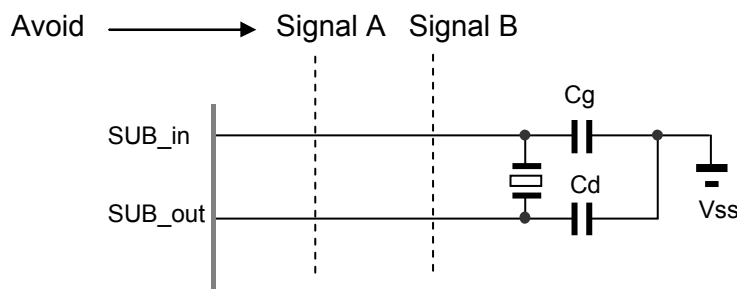

Figure 2 Example of Incorrect Board Design

**Remark** When using the subsystem clock, insert resistors Rd in series on the SUB\_out side.



## Evaluation of Subsystem Clock Oscillation Circuit

[M3455AGCFP-52P] LQFP(10x10) 0.65mm pitch

Measurement conditions :5.0V,3.0V



### [Evaluation Sample : VT-200 6.0pF at 25°C]

SAMPLE	No.	CL ( pF )	Fo( Hz )	fr( Hz )	R1( kohm )	Co( pF )	C1( fF )	Q( k )
VT-200 6.0pF	1	6	32767.90	32762.79	28.8	0.88	2.148	78.6
	2	6	32768.18	32763.04	27.8	0.89	2.161	80.9
	3	6	32768.01	32762.79	28.0	0.90	2.199	78.9

### [IC Test Data : IC sample Rd=330k ohm,Cg=8pF,Cd=7pF at 25°C]

Vcc(V)	IC sample	Fosc( Hz )	df / f( x10 <sup>-6</sup> )	DL(x10 <sup>-6</sup> W)	-RL  ( kohm )	Vstart( V )	Ts(sec)
5.0	TYP	32768.090	2.44	0.01	857	1.05	0.36
	HH	32768.133	3.75	0.03	947	1.36	0.24
	LL	32768.022	0.37	0.02	1037	0.86	0.36

### [IC Test Data : IC sample Rd=330k ohm,Cg=8pF,Cd=7pF at 25°C]

Vcc(V)	IC sample	Fosc( Hz )	df / f( x10 <sup>-6</sup> )	DL(x10 <sup>-6</sup> W)	-RL  ( kohm )	Vstart( V )	Ts(sec)
3.0	TYP	32768.043	1.01	0.01	2037	1.05	0.30
	HH	32767.890	-3.66	0.03	2237	1.36	0.24
	LL	32768.058	1.46	0.02	1537	0.86	0.29

### Remark ( see figure 3 )

$$F_o = f_r \times \{ C_1 / ( 2 \times ( C_o + C_L ) ) + 1 \} \text{ ( Hz )}$$

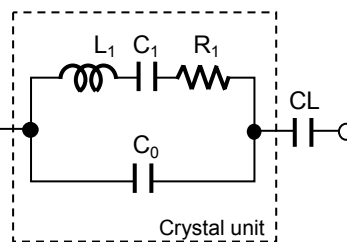

Fo : Load resonance frequency  
fr : Resonance frequency  
R1 : Motional resistance  
C1 : Motional capacitance  
Co : Shunt capacitance  
CL : Load Capacitance

Figure 3 Equivalent circuit of crystal unit, and CL

### Remark ( see figure 4 )

Approximate formula of the load capacitance of the circuit CL.

$$C_L = C_g \times C_d / ( C_g + C_d ) + C_s \text{ ( pF )}$$

Where Cs(=2 to 4pF) Stands for stray capacitance of the circuit.

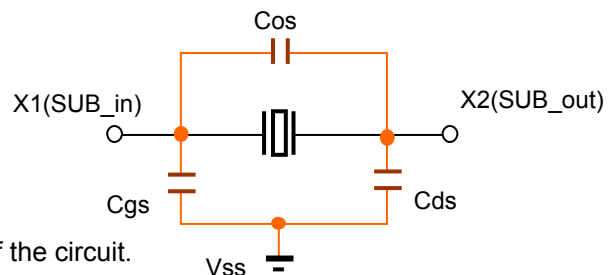

Cos : X1\_X2 Stray capacitance  
Cgs : X1\_Vss Stray capacitance  
Cds : X2\_Vss Stray capacitance

Figure 4 Stray capacitance Cos,Cgs,Cds of the circuit

Resonator circuit constants will differ depending on the resonator element, stray capacitance in its interconnecting circuit, and other factors. Suitable constants should be determined in consultation with the resonator element manufacturer.



# Evaluation of Subsystem Clock Oscillation Circuit

[M3455AGCFP] LQFP(10x10) 0.65mm pitch  
 Measurement conditions : Vcc=(1.5V) to 5.5V at 25°C

## Referential Data : Voltage characteristics

