

Evaluation of Subsystem Clock Oscillation Circuit

[MB91F647-176P] LQFP(24x24) 0.50mm pitch

Measurement conditions :3.3V , (2.2V)reference

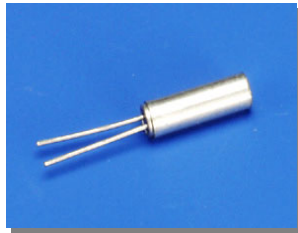

Model :VT-200
 Frequency :Fo=32.768kHz
 Frequency tolerance :dF/Fo= +/-20x10⁶
 Load capacitance :CL=6.0pF
 Equivalent series resistance :R1=50kohm max
 Max. drive level :DL=1x10⁶W max
 Level of drive :DL=0.1x10⁶W typ

FEATURES

- 1.Compact tubular package
- 2.Photolithographic process
- 3.Excellent shock resistance and environmental characteristics.
- 4.Real time clocks, Timers, Portable applications

DIMENSIONS(VT-200)

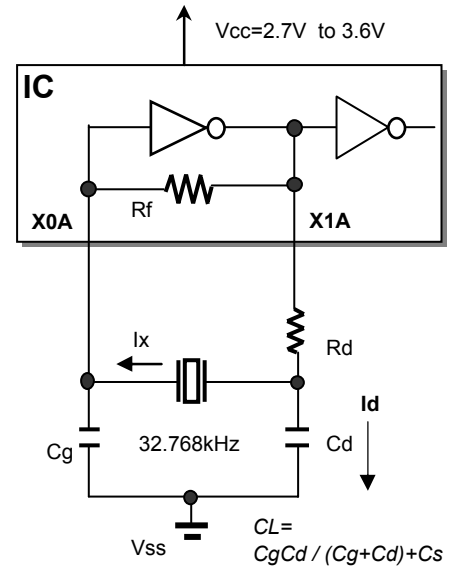
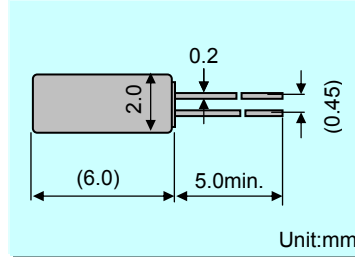

Remark) Ix : current through crystal

MODEL:VT-200 6.0pF with MB91F647 at 25°C

Key specifications	Vcc=(2.2V)	Vcc=3.3V	Remarks
Current control resistance : Rd (k ohm)	330	330	Control drive level & secure phase margin
Capacitance at gate : Cg (pF)	7	7	Optimal capacitance in response to CL
Capacitance at drain : Cd (pF)	6	6	(CL = Cd // Cg + stray capacitance)

Circuit characteristics (at 25°C)	Vcc=(2.2V)	Vcc=3.3V	Remarks
Matching Accuracy : df / f (x10 ⁻⁶)	-14.3	2.1	Frequency offset volume at specified Vcc
Voltage Fluctuation : +/-df / V (x10 ⁻⁶)	4.1	2.7	Vcc +/-10% (Standard operating voltage range)
Drive Level : DL (x10 ⁶ W)	0.03	0.02	DL=Ix ² Re < 1x10 ⁶ W, Re=R1(1 + Co / CL) ²
Negative resistance : - RL (kohm)	947	787	5 times larger than R _{1MAX}
Oscillation allowance : M (times)	19	16	Judgemental standard of oscillation stability
consumption current : Id (nA)	746	1,073	Cd charge current, Id = ωCd*Vd
Voltage of oscillation start : Vstart (V)	1.44	1.44	
Voltage of oscillation stop : Vstop (V)	1.21	1.21	
Oscillation start up time : Ts (sec)	0.41	0.50	Time to reach 90% of output level

Temperature characteristics of circuit		Vcc=(2.2V)	Vcc=3.3V	Remarks
at -40°C	Variation : df / T (x10 ⁻⁶)	-138	-138	Typ.Tp=25°C (K = -3.5x10 ⁻⁸ / °C ²)
at +85°C	Variation : df / T (x10 ⁻⁶)	-128	-129	Typ.Tp=25°C (K = -3.5x10 ⁻⁸ / °C ²)

The above mentioned value is only for your reference. The value is for the arbitrary samples and does not guarantee the product's characteristics. Please review and check above parameters at customer's end.

Seiko Instruments USA Inc.

2990,West Lomita Blvd., Torrance, CA 90505, U.S.A
 Telephone :+1 310-517-7771 Facsimile :+1 310-517-7792
 Email :info@siu-la.com

Seiko Instruments GmbH

Siemensstrasse 9,D-63263 Neu-Isenburg,Germany
 Telephone :+49-6102-297-0 Facsimile :+49-6102-297-320
 Email :info@seiko-instruments.de

Seiko Instruments Inc.

1-8,Nakase,Mihama-ku,Chiba-shi,Chiba 261-8507,Japan
 Facsimile :+81-43-211-8030
 E-mail :component@sii.co.jp

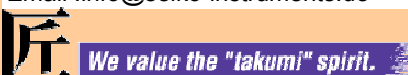

Evaluation of Subsystem Clock Oscillation Circuit

[MB91F647-176P] LQFP(24x24) 0.50mm pitch
 Measurement conditions :3.3V , (2.2V)reference



Test Data at 25°C

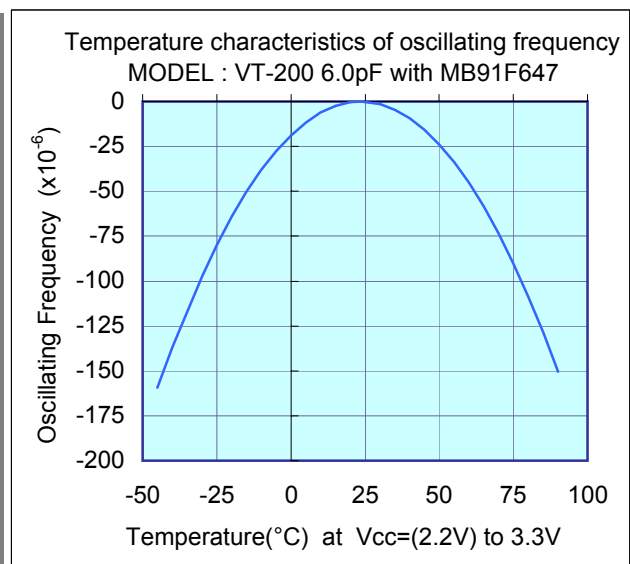
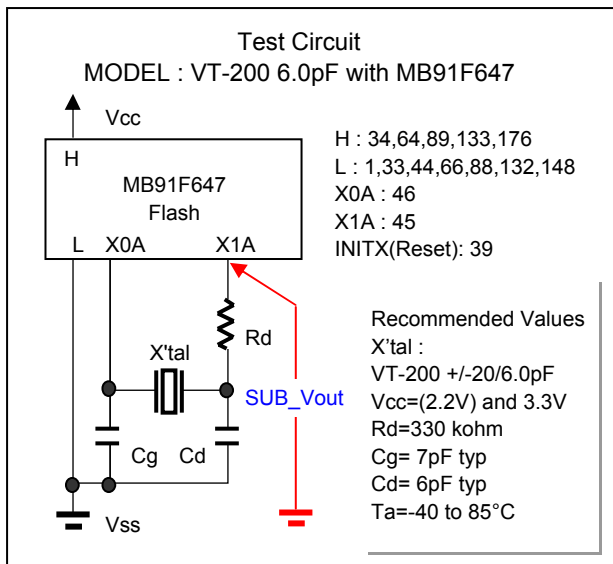
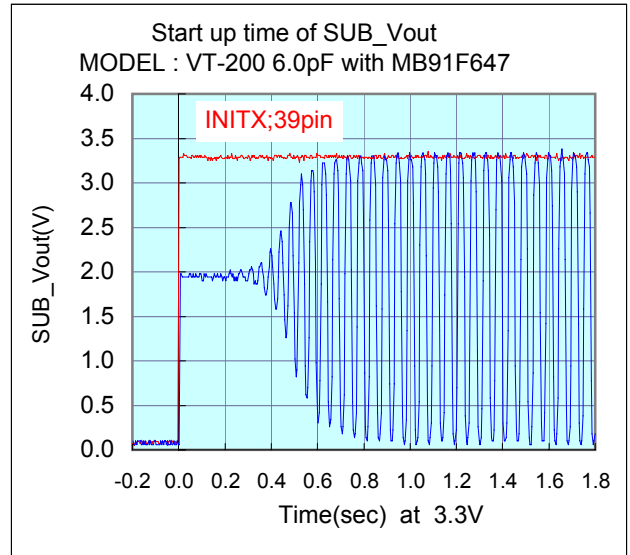
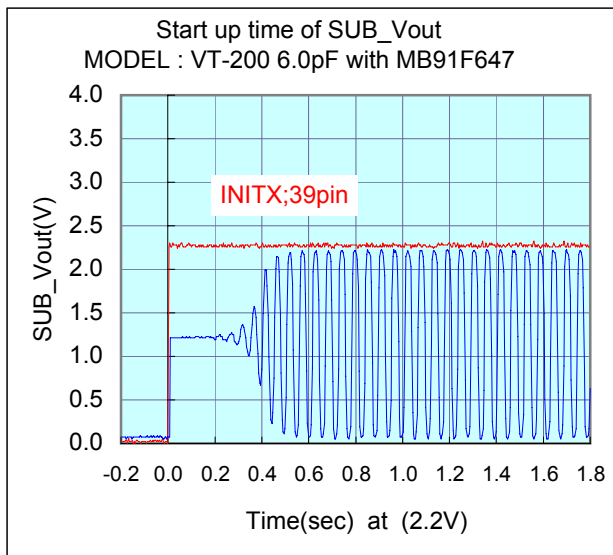
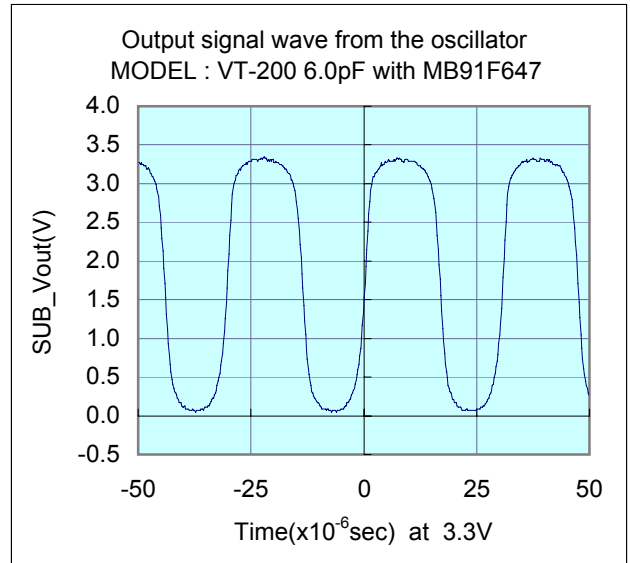
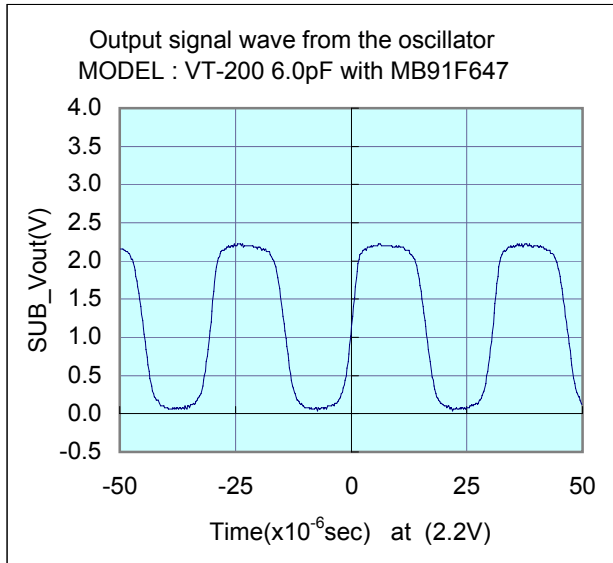

Evaluation of Subsystem Clock Oscillation Circuit

[MB91F647-176P] LQFP(24x24) 0.50mm pitch
 Measurement conditions :3.3V , (2.2V)reference



Test Data : Temperature characteristics

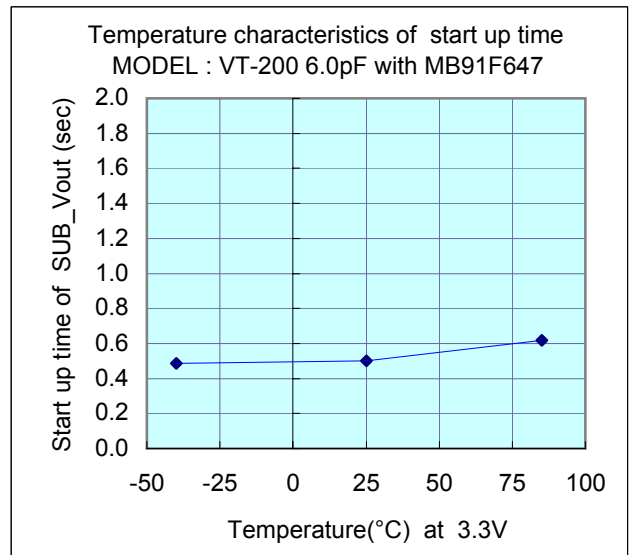
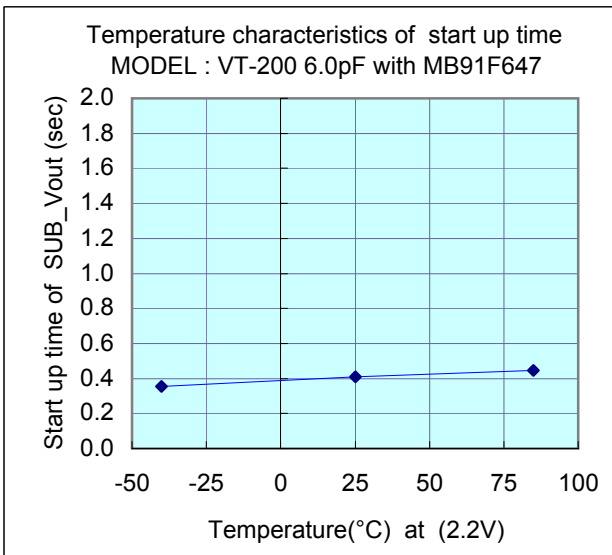
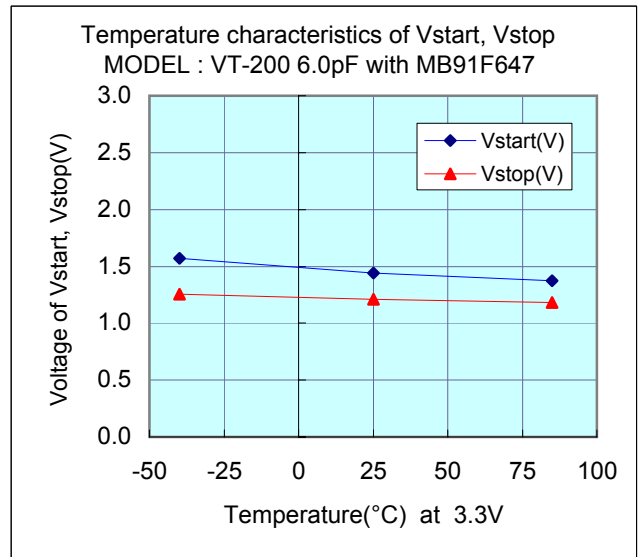
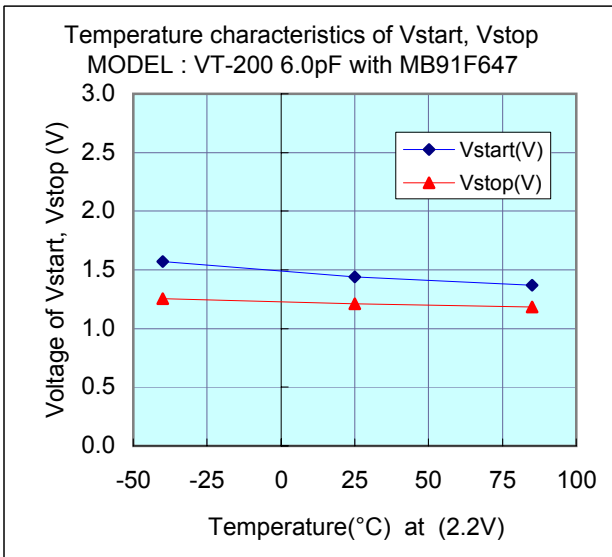
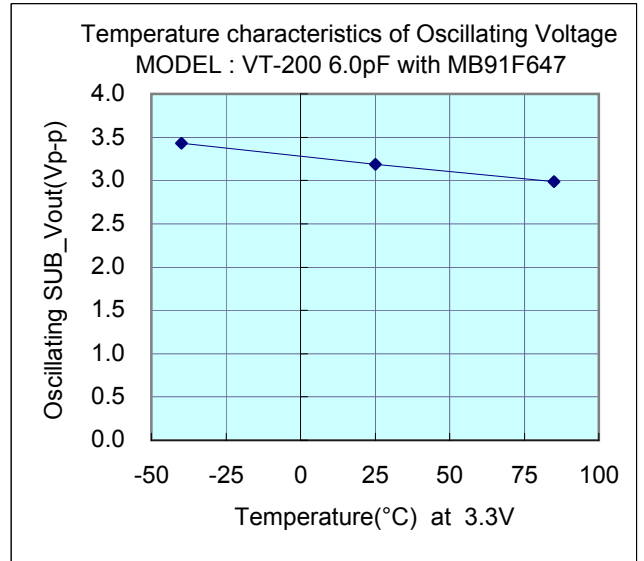
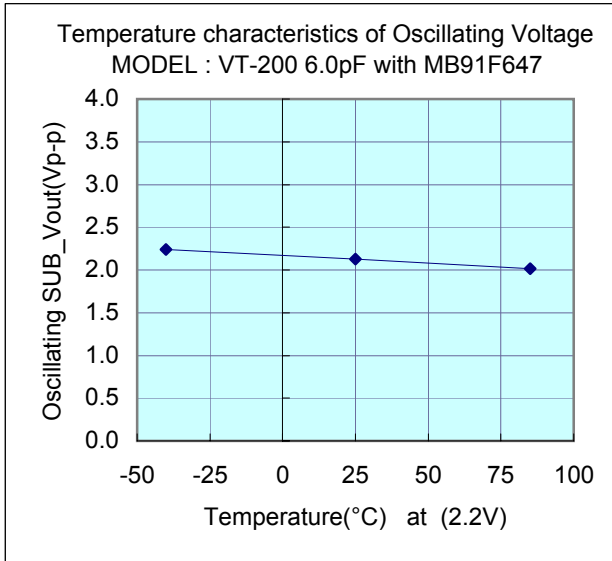

Evaluation of Subsystem Clock Oscillation Circuit

[MB91F647-176P] LQFP(24x24) 0.50mm pitch
 Measurement conditions :3.3V , (2.2V)reference



Referential components layout(see Figure 1)

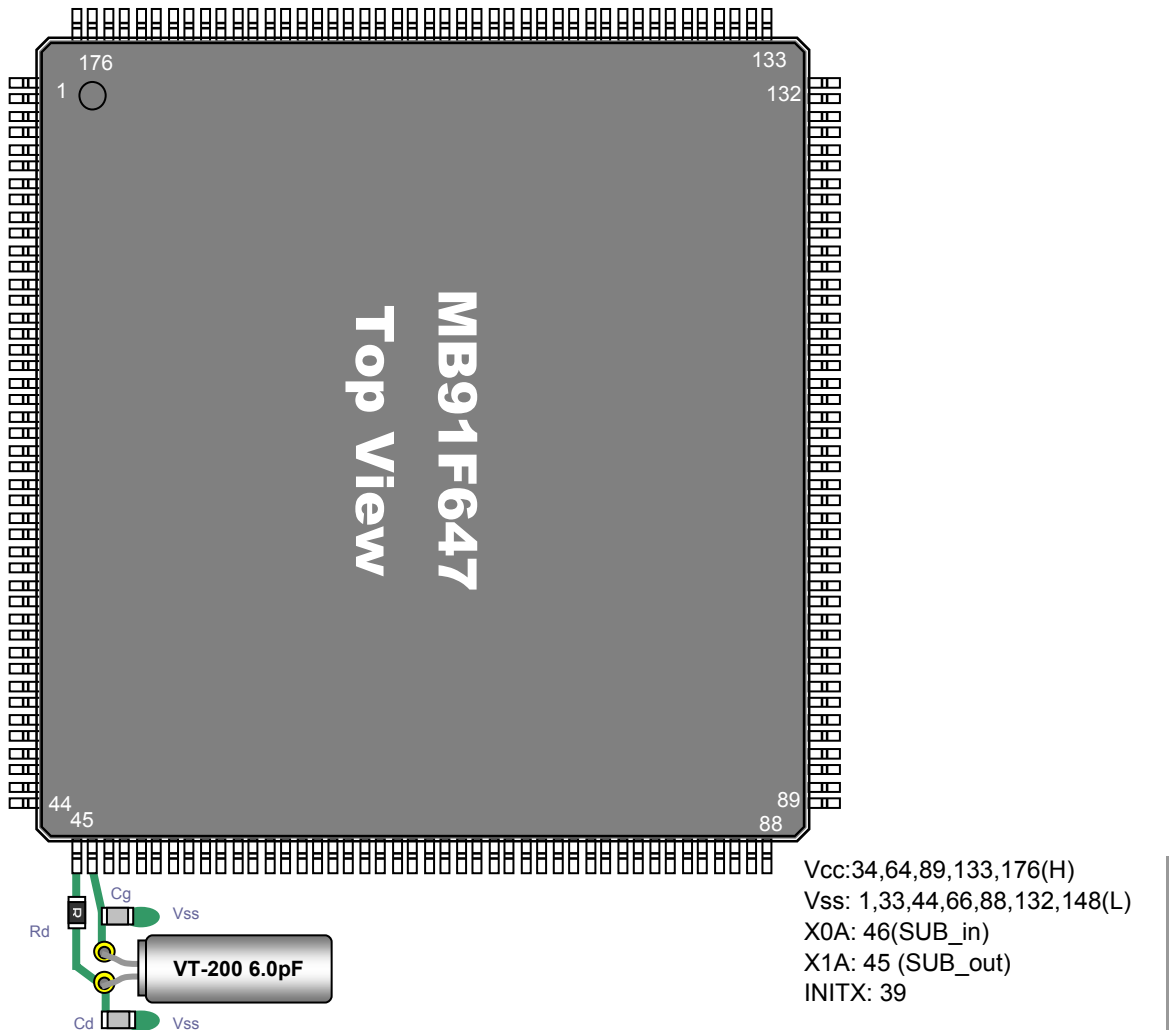

Figure 1 Referential components layout

Notes for Board Design

When using a crystal resonator, place the resonator and its load capacitors as close as possible to SUB_in and SUB_out pins.
 Other signal lines should be routed away from the resonator circuit to prevent induction from interfering with correct oscillation (see figure 2).

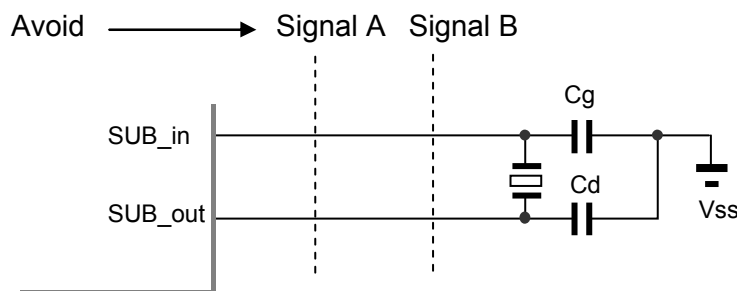

Figure 2 Example of Incorrect Board Design

Remark When using the subsystem clock, insert resistors Rd in series on the SUB_out side.

Evaluation of Subsystem Clock Oscillation Circuit

[MB91F647-176P] LQFP(24x24) 0.50mm pitch
 Measurement conditions :3.3V , (2.2V)reference



[Evaluation Sample : VT-200 6.0pF at 25°C]

SAMPLE	No.	CL(pF)	Fo(Hz)	fr(Hz)	R1(kohm)	Co(pF)	C1(fF)	Q(k)
VT-200 6.0pF	1	6	32767.90	32762.75	26.7	0.89	2.166	84.0
	2	6	32767.99	32762.80	27.9	0.90	2.186	79.7
	3	6	32768.01	32762.79	28.0	0.90	2.199	78.9

[IC Test Data : IC sample Rd=330k ohm,Cg=7pF,Cd=6pF at 25°C]

Vcc(V)	IC sample	Fosc(Hz)	df / f(x10 ⁻⁶)	DL(x10 ⁻⁶ W)	RL(kohm)	Vstart(V)	Ts(sec)
3.3	TYP_#1	32768.080	2.14	0.02	787	1.44	0.50
	TYP_#2	32768.100	2.75	0.02	787	1.44	0.50
	TYP_#3	32768.080	2.14	0.02	787	1.44	0.49

[IC Test Data : IC sample Rd=330k ohm,Cg=(7pF),Cd=(6pF) at 25°C]

Vcc(V)	IC sample	Fosc(Hz)	df / f(x10 ⁻⁶)	DL(x10 ⁻⁶ W)	RL(kohm)	Vstart(V)	Ts(sec)
(2.2)	TYP_#1	32767.540	-14.34	0.03	947	1.44	0.41
	TYP_#2	32767.560	-13.73	0.03	947	1.44	0.45
	TYP_#3	32767.550	-14.04	0.03	857	1.44	0.40

Remark (see figure 3)

$$F_o = f_r \times \{ C_1 / (2 \times (C_o + C_L)) + 1 \} \text{ (Hz)}$$

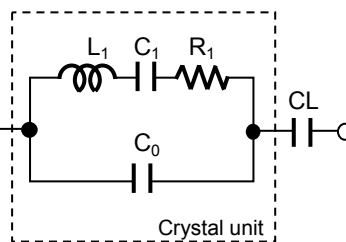

- Fo : Load resonance frequency
- fr : Resonance frequency
- R1 : Motional resistance
- C1 : Motional capacitance
- Co : Shunt capacitance
- CL : Load Capacitance

Figure 3 Equivalent circuit of crystal unit, and CL

Remark (see figure 4)

Approximate formula of the load capacitance of the circuit CL.

$$CL = C_g \times C_d / (C_g + C_d) + C_s \text{ (pF)}$$

Where Cs(=2 to 4pF) Stands for stray capacitance of the circuit.

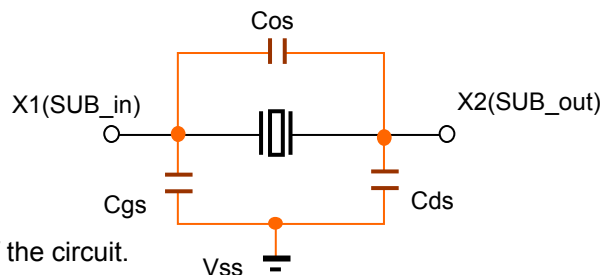

- Cos : X1_X2 Stray capacitance
- Cgs : X1_Vss Stray capacitance
- Cds : X2_Vss Stray capacitance

Figure 4 Stray capacitance Cos,Cgs,Cds of the circuit

Resonator circuit constants will differ depending on the resonator element, stray capacitance in its interconnecting circuit, and other factors. Suitable constants should be determined in consultation with the resonator element manufacturer.

Evaluation of Subsystem Clock Oscillation Circuit

[MB91F647-176P] LQFP(24x24) 0.50mm pitch

Measurement conditions : Vcc=(1.8V) to 3.6V at 25°C



Referential Data : Voltage characteristics

