

# Evaluation of Subsystem Clock Oscillation Circuit

[MB91F647-176P] LQFP(24x24) 0.50mm pitch

Measurement conditions :3.3V , (2.2V)reference

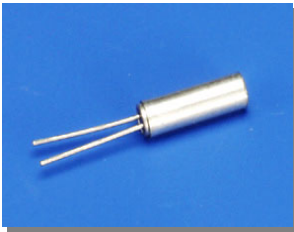

Model	:VT-200
Frequency	:Fo=32.768kHz
Frequency tolerance	:dF/Fo= +/-20x10 <sup>6</sup>
Load capacitance	:CL=12.5pF
Equivalent series resistance	:R1=50kohm max
Max. drive level	:DL=1x10 <sup>6</sup> W max
Level of drive	:DL=0.1x10 <sup>6</sup> W typ

## FEATURES

- 1.Compact tubular package
- 2.Photolithographic process
- 3.Excellent shock resistance and environmental characteristics.
- 4.Real time clocks, Timers, Portable applications

## DIMENSIONS(VT-200)

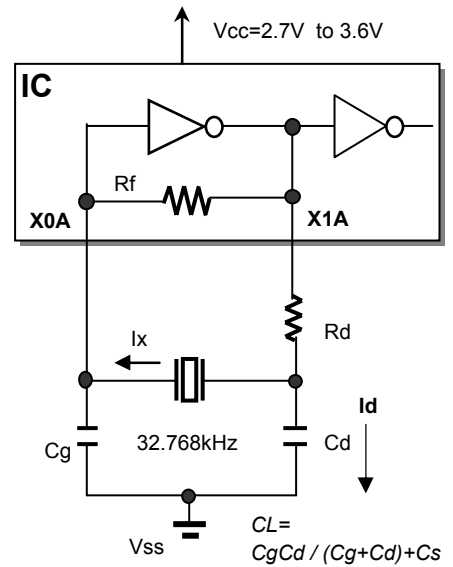
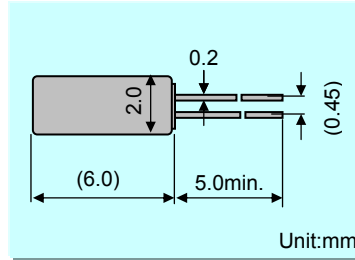

Remark) Ix : current through crystal

MODEL:VT-200 12.5pF with MB91F647 at 25°C

Key specifications	Vcc=(2.2V)	Vcc=3.3V	Remarks
Current control resistance : Rd ( k ohm )	220	220	Control drive level & secure phase margin
Capacitance at gate : Cg ( pF )	22	22	Optimal capacitance in response to CL
Capacitance at drain : Cd ( pF )	18	18	( CL = Cd // Cg + stray capacitance )

Circuit characteristics ( at 25°C )	Vcc=(2.2V)	Vcc=3.3V	Remarks
Matching Accuracy : df / f ( x10 <sup>-6</sup> )	-4.9	0.6	Frequency offset volume at specified Vcc
Voltage Fluctuation : +/-df / V ( x10 <sup>-6</sup> )	1.2	0.8	Vcc +/-10% ( Standard operating voltage range )
Drive Level : DL ( x10 <sup>-6</sup> W )	0.20	0.30	DL=Ix <sup>2</sup> Re < 1x10 <sup>-6</sup> W, Re=R1( 1 + Co / CL ) <sup>2</sup>
Negative resistance :   - RL   ( kohm )	392	782	5 times larger than R1MAX
Oscillation allowance : M ( times )	8	16	Judgemental standard of oscillation stability
consumption current : Id (nA)	1,546	2,314	Cd charge current, Id = ωCd*Vd
Voltage of oscillation start : Vstrat ( V )	1.55	1.55	
Voltage of oscillation stop : Vstop ( V )	1.29	1.29	
Oscillation start up time : Ts ( sec )	0.78	0.45	Time to reach 90% of output level

Temperature characteristics of circuit		Vcc=(2.2V)	Vcc=3.3V	Remarks
at -40°C	Variation : df / T ( x10 <sup>-6</sup> )	-139	-139	Typ.Tp=25°C ( K = -3.5x10 <sup>-8</sup> / °C <sup>2</sup> )
at +85°C	Variation : df / T ( x10 <sup>-6</sup> )	-127	-128	Typ.Tp=25°C ( K = -3.5x10 <sup>-8</sup> / °C <sup>2</sup> )

The above mentioned value is only for your reference. The value is for the arbitrary samples and does not guarantee the product's characteristics. Please review and check above parameters at customer's end.

### Seiko Instruments USA Inc.

2990,West Lomita Blvd., Torrance, CA 90505, U.S.A  
 Telephone :+1 310-517-7771 Facsimile :+1 310-517-7792  
 Email :info@siu-la.com

### Seiko Instruments GmbH

Siemensstrasse 9,D-63263 Neu-Isenburg,Germany  
 Telephone :+49-6102-297-0 Facsimile :+49-6102-297-320  
 Email :info@seiko-instruments.de

### Seiko Instruments Inc.

1-8,Nakase,Mihama-ku,Chiba-shi,Chiba 261-8507,Japan  
 Facsimile :+81-43-211-8030  
 E-mail :component@sii.co.jp



# Evaluation of Subsystem Clock Oscillation Circuit

[MB91F647-176P] LQFP(24x24) 0.50mm pitch  
 Measurement conditions :3.3V , (2.2V)reference



## Test Data at 25°C

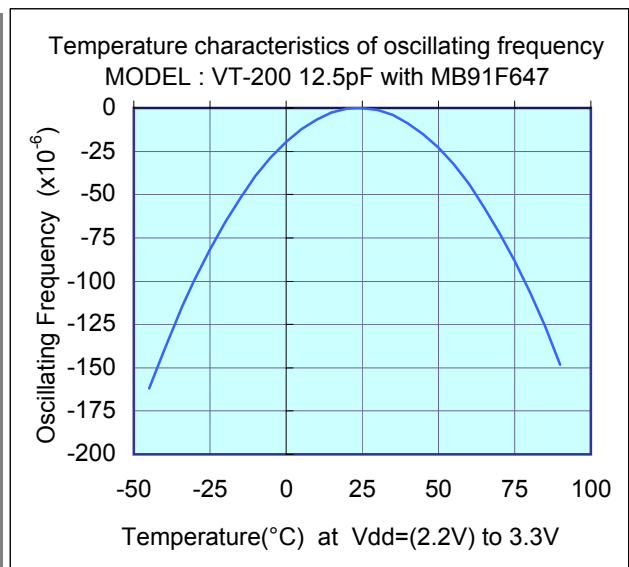
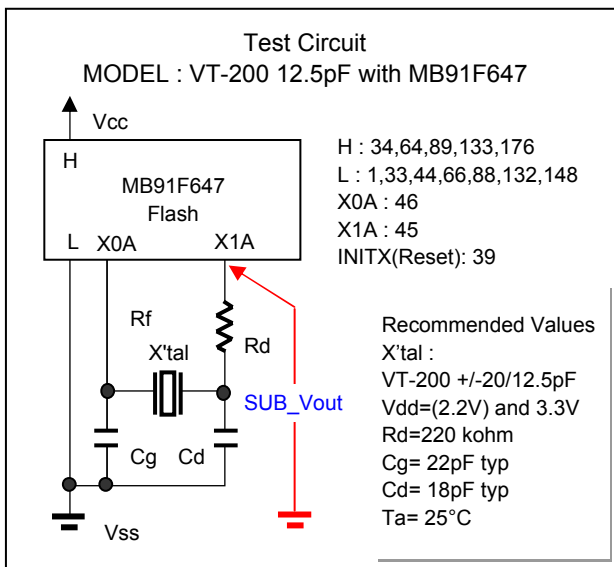
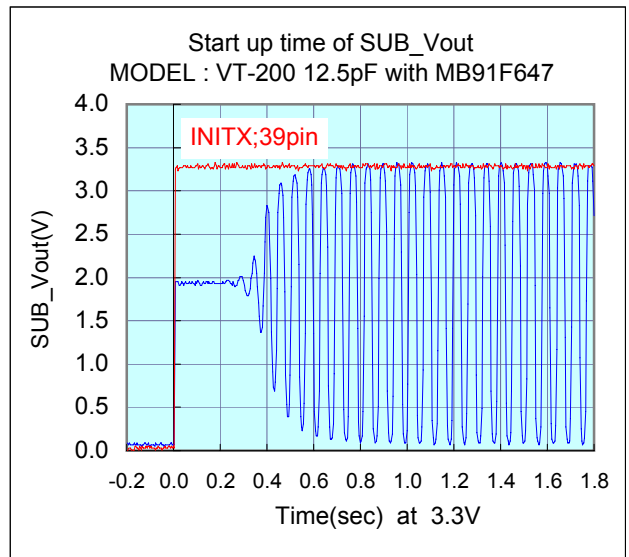
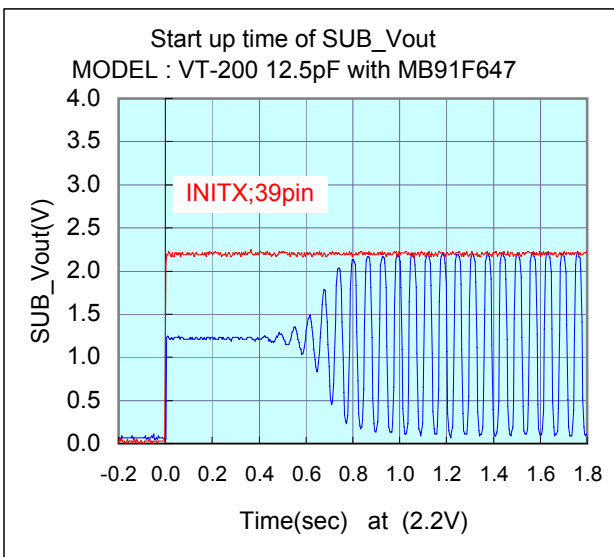
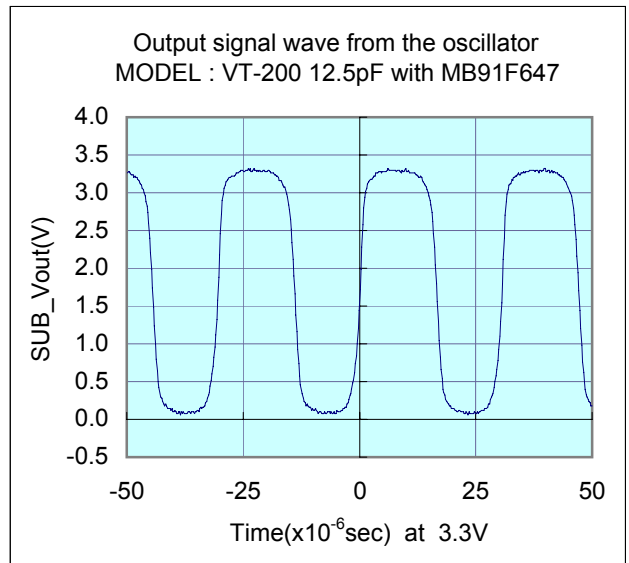
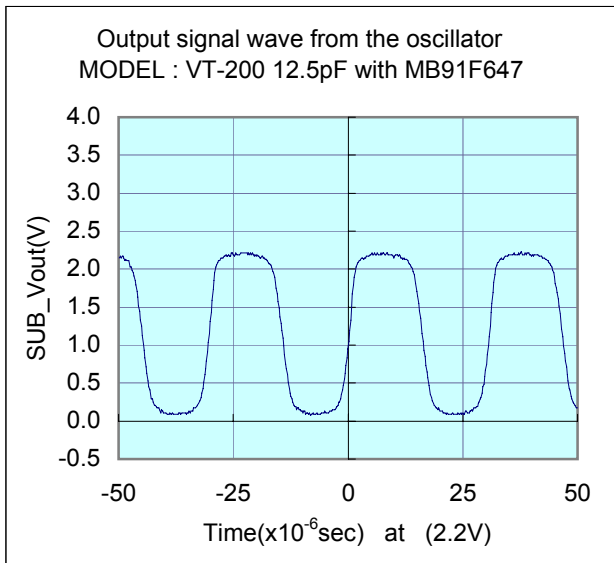

# Evaluation of Subsystem Clock Oscillation Circuit

[MB91F647-176P] LQFP(24x24) 0.50mm pitch  
 Measurement conditions :3.3V , (2.2V)reference



## Test Data : Temperature characteristics

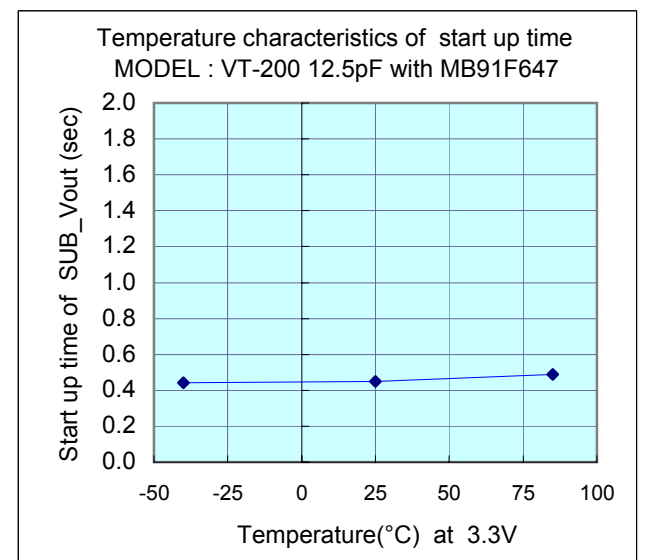
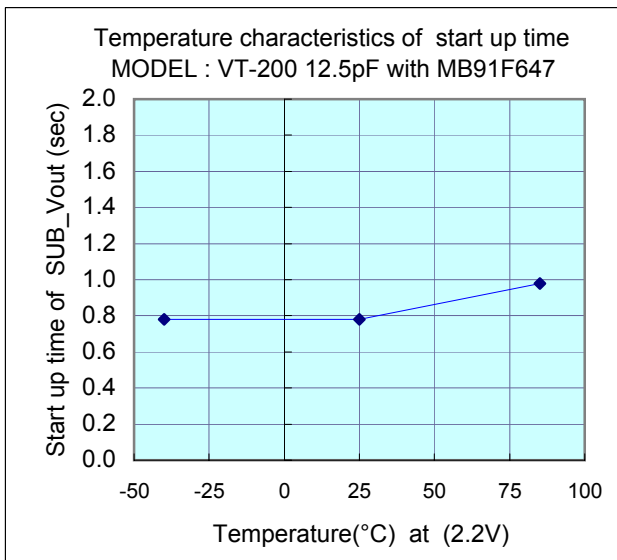
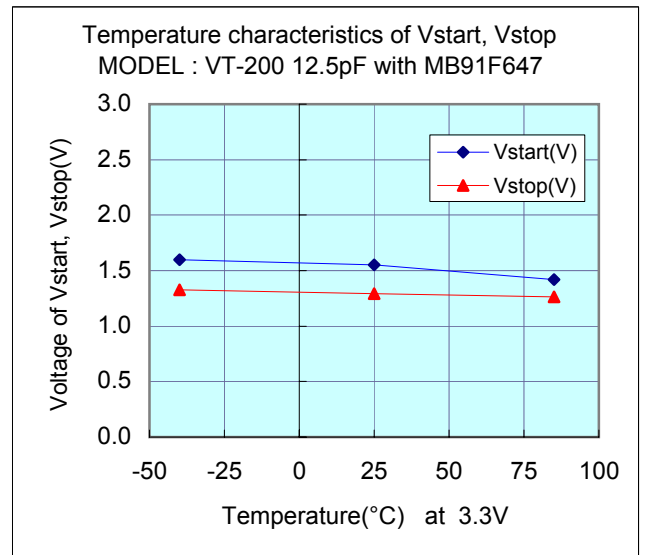
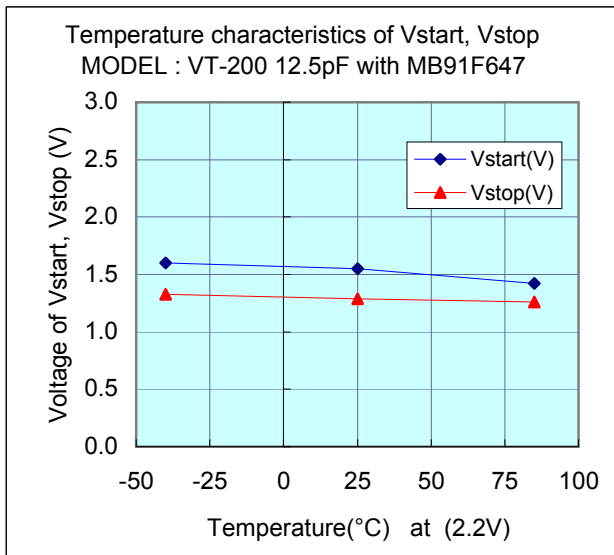
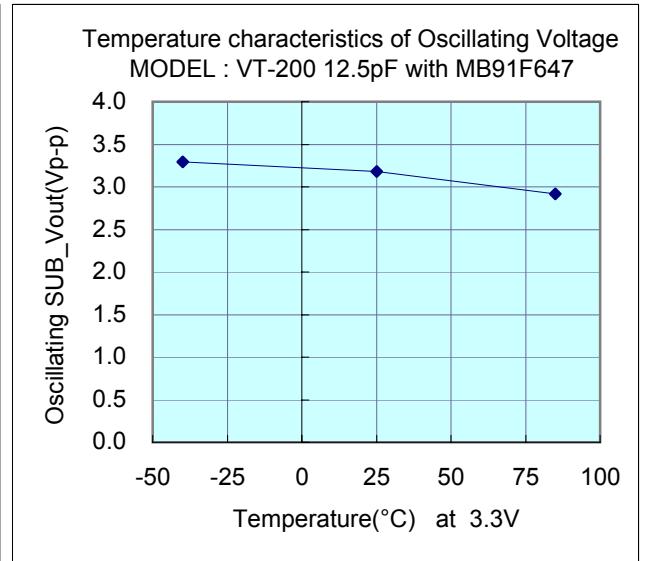
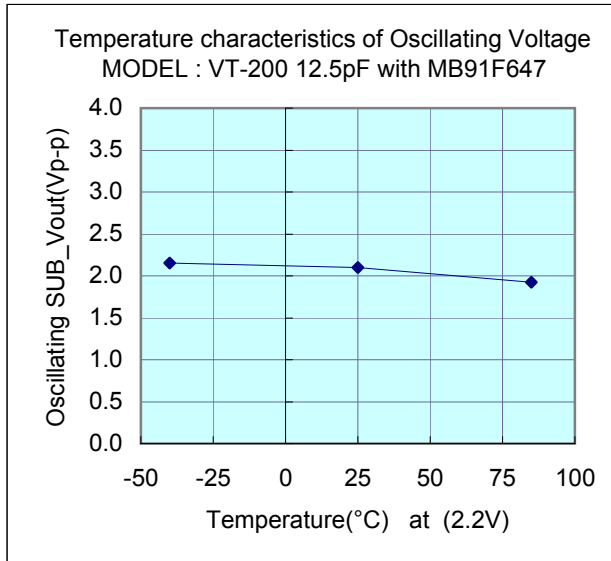

# Evaluation of Subsystem Clock Oscillation Circuit

[MB91F647-176P] LQFP(24x24) 0.50mm pitch  
 Measurement conditions :3.3V , (2.2V)reference



## Referential components layout(see Figure 1)

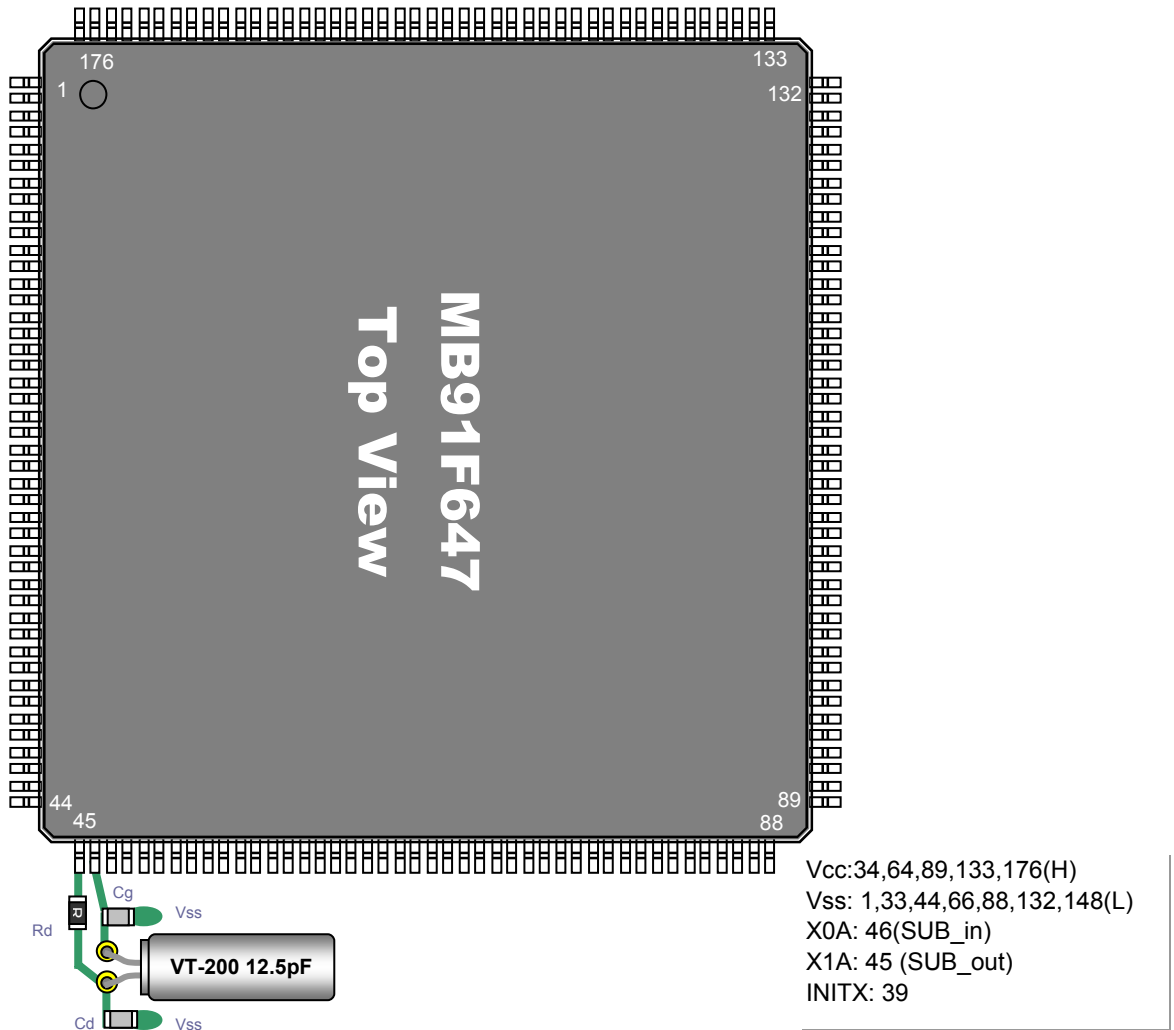

Figure 1 Referential components layout

## Notes for Board Design

When using a crystal resonator, place the resonator and its load capacitors as close as possible to SUB\_in and SUB\_out pins.

Other signal lines should be routed away from the resonator circuit to prevent induction from interfering with correct oscillation (see figure 2).

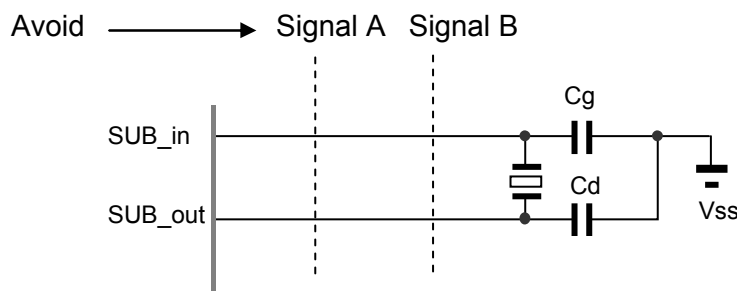

Figure 2 Example of Incorrect Board Design

**Remark** When using the subsystem clock, insert resistors Rd in series on the SUB\_out side.

Evaluation of Subsystem Clock Oscillation Circuit



[MB91F647-176P] LQFP(24x24) 0.50mm pitch  
 Measurement conditions :3.3V , (2.2V)reference

[Evaluation Sample : VT-200 12.5pF at 25°C]

SAMPLE	No.	CL( pF )	Fo( Hz )	fr( Hz )	R1( kohm )	Co( pF )	C1( fF )	Q( k )
VT-200 12.5pF	1	12.5	32768.30	32765.60	27.8	0.89	2.207	79.2
	2	12.5	32767.83	32765.10	29.0	0.90	2.233	75.0
	3	12.5	32768.38	32765.60	30.0	0.92	2.277	71.1

[IC Test Data : IC sample Rd=220k ohm,Cg=22pF,Cd=18pF at 25°C]

Vcc(V)	IC sample	Fosc( Hz )	df / f( x10 <sup>-6</sup> )	DL(x10 <sup>-6</sup> W)	-RL  ( kohm )	Vstart( V )	Ts(sec)
3.3	TYP_#1	32768.320	0.61	0.30	782	1.55	0.45
	TYP_#2	32768.330	0.92	0.30	782	1.55	0.44
	TYP_#3	32768.320	0.61	0.30	782	1.55	0.44

[IC Test Data : IC sample Rd=220k ohm,Cg=(22pF),Cd=(18pF) at 25°C]

Vcc(V)	IC sample	Fosc( Hz )	df / f( x10 <sup>-6</sup> )	DL(x10 <sup>-6</sup> W)	-RL  ( kohm )	Vstart( V )	Ts(sec)
(2.2)	TYP_#1	32768.140	-4.88	0.20	392	1.55	0.78
	TYP_#2	32768.144	-4.76	0.20	392	1.55	0.80
	TYP_#3	32768.140	-4.88	0.20	392	1.55	0.75

Remark ( see figure 3 )

$$F_o = f_r \times \{ C_1 / ( 2 \times ( C_o + C_L ) ) + 1 \} \text{ ( Hz )}$$

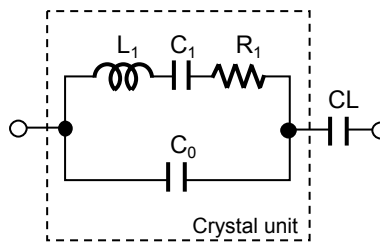

- Fo : Load resonance frequency
- fr : Resonance frequency
- R1 : Motional resistance
- C1 : Motional capacitance
- Co : Shunt capacitance
- CL : Load Capacitance

Figure 3 Equivalent circuit of crystal unit, and CL

Remark ( see figure 4)

Approximate formula of the load capacitance of the circuit CL.

$$CL = C_g \times C_d / ( C_g + C_d ) + C_s \text{ ( pF )}$$

Where Cs(=2 to 4pF) Stands for stray capacitance of the circuit.

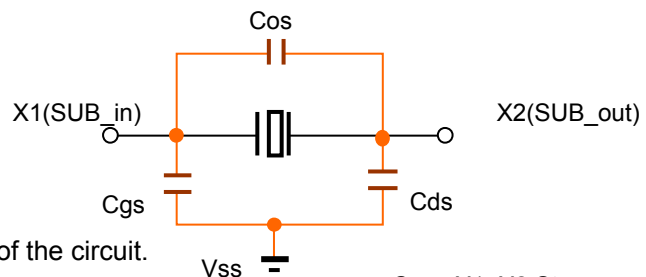

- Cos : X1\_X2 Stray capacitance
- Cgs : X1\_Vss Stray capacitance
- Cds : X2\_Vss Stray capacitance

Figure 4 Stray capacitance Cos,Cgs,Cds of the circuit

Resonator circuit constants will differ depending on the resonator element, stray capacitance in its interconnecting circuit, and other factors. Suitable constants should be determined in consultation with the resonator element manufacturer.

**Evaluation of Subsystem Clock Oscillation Circuit**

[MB91F647-176P] LQFP(24x24) 0.50mm pitch

Measurement conditions : Vcc=(1.8V) to 3.6V at 25°C



**Referential Data : Voltage characteristics**

