

Evaluation of Low Frequency Clock Oscillation Circuit

SSP-T7 7.0pF with MB95107A-64P [LQFP(10x10) 0.50mm pitch]

Measurement conditions :3.0V , 2.2V



Model :SSP-T7
 Frequency :Fo=32.768kHz
 Frequency tolerance :dF/Fo= +/-20x10-6
 Load capacitance :CL=7.0pF
 Equivalent series resistance :R1=65kohm max
 Max. drive level :DL=1x10⁻⁶W max
 Level of drive :DL=0.1x10⁻⁶W typ

FEATURES

- 1.Ultra thin type with 1.4mm Max.
- 2.SMD type suitable for automatic & high density surface mounting.
- 3.Plastic mold package containing highly reliable tubular type quartz crystal.
- 4.Excellent shock and heat resistance.
- 5.Cellular phones,PDA, Radio communication equipment, Portable applications etc.

RECOMMENDED SOLDERING PATTERN

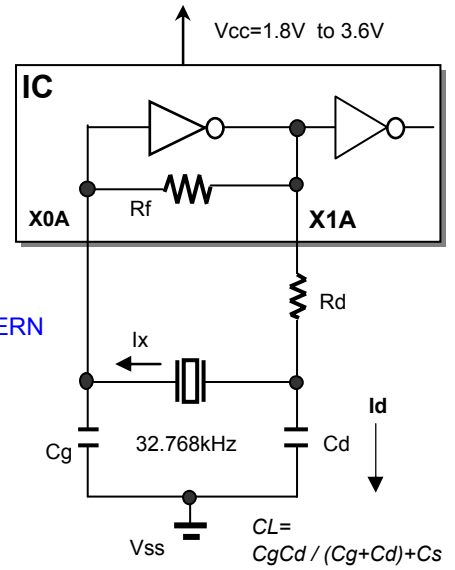
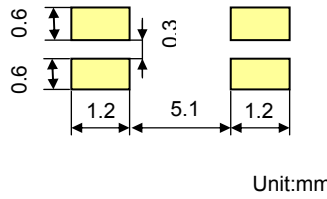

Remark) Ix : current through crystal

MODEL:SSP-T7 7.0pF with MB95107A at 25°C

Key specifications	Vcc=2.2V	Vcc=3.0V	Remarks
Current control resistance : Rd (k ohm)	0	0	Control drive level & secure phase margin
Capacitance at gate : Cg (pF)	8	8	Optimal capacitance in response to CL
Capacitance at drain : Cd (pF)	8	8	(CL = Cd // Cg + stray capacitance)

Circuit characteristics (at 25°C)	Vcc=2.2V	Vcc=3.0V	Remarks
Matching Accuracy : df / f (x10 ⁻⁶)	-0.4	0.9	Frequency offset volume at specified Vcc
Voltage Fluctuation : +/-df / V (x10 ⁻⁶)	0.3	0.6	Vcc +/-10% (Standard operating voltage range)
Drive Level : DL (x10 ⁻⁶ W)	0.02	0.02	DL=Ix ² Re < 1x10 ⁻⁶ W, Re=R1(1 + Co / CL) ²
Negative resistance : - RL (kohm)	1553	1653	5 times larger than R _{1MAX}
Oscillation allowance : M (times)	24	25	Judgemental standard of oscillation stability
consumption current : Id (nA)	346	348	Cd charge current, Id = ωCd*Vd
Voltage of oscillation start : Vstart (V)	1.23	1.23	
Voltage of oscillation stop : Vstop (V)	0.93	0.93	
Oscillation start up time : Ts (sec)	0.65	0.62	Time to reach 90% of output level

Temperature characteristics of circuit		Vcc=2.2V	Vcc=3.0V	Remarks
at -40°C	Variation : df / T (x10 ⁻⁶)	-131	-131	Typ.Tp=25°C (K = -3.5x10 ⁻⁸ / °C ²)
at +85°C	Variation : df / T (x10 ⁻⁶)	-132	-132	Typ.Tp=25°C (K = -3.5x10 ⁻⁸ / °C ²)

The above mentioned value is only for your reference. The value is for the arbitrary samples and does not guarantee the product's characteristics. Please review and check above parameters at customer's end.

Seiko Instruments USA Inc.

2990,West Lomita Blvd., Torrance, CA 90505, U.S.A
 Telephone :+1 310-517-7771 Facsimile :+1 310-517-7792
 Email :info@siu-la.com

Seiko Instruments GmbH

Siemensstrasse 9,D-63263 Neu-Isenburg,Germany
 Telephone :+49-6102-297-0 Facsimile :+49-6102-297-320
 Email :info@seiko-instruments.de

Seiko Instruments Inc.

1-8,Nakase,Mihama-ku,Chiba-shi,Chiba 261-8507,Japan
 Facsimile :+81-43-211-8030
 E-mail :component@sii.co.jp



We value the "takumi" spirit.

Seiko Instruments Inc.

Phone:+81-43-211-1207(Direct)

Evaluation of Low Frequency Clock Oscillation Circuit

SSP-T7 7.0pF with MB95107A-64P [LQFP(10x10) 0.50mm pitch]

Measurement conditions :3.0V , 2.2V



Test Data at 25°C

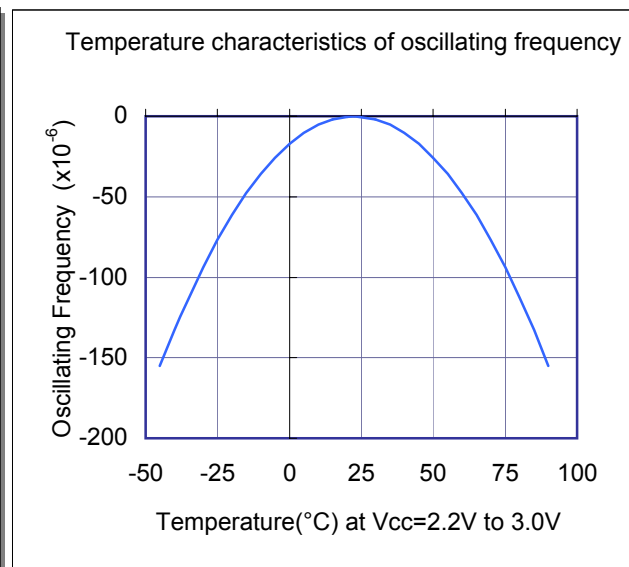
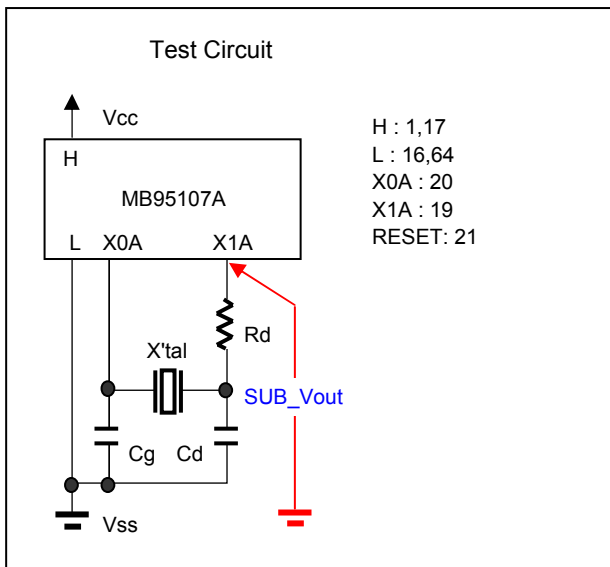
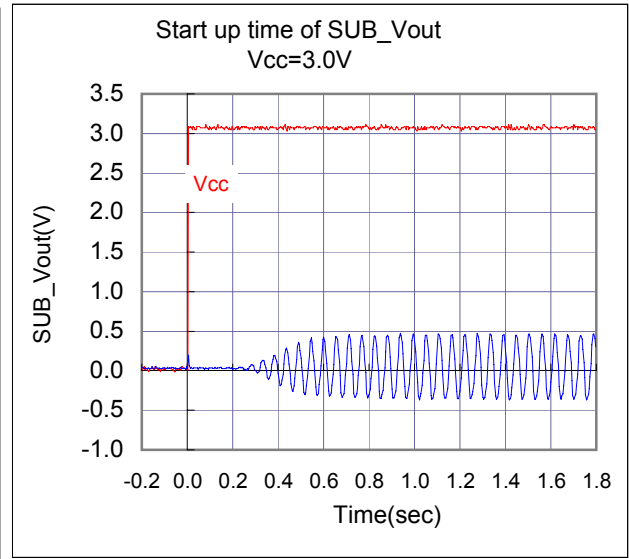
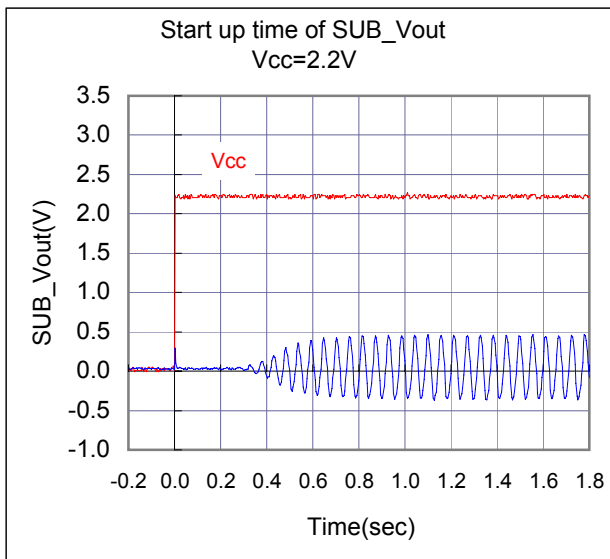
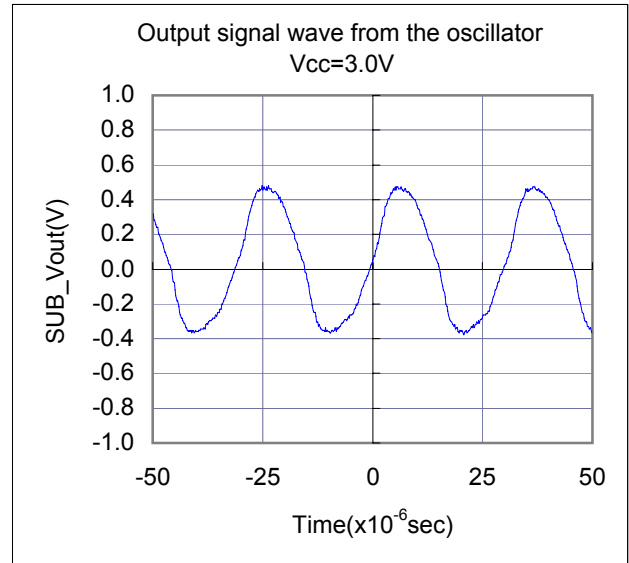
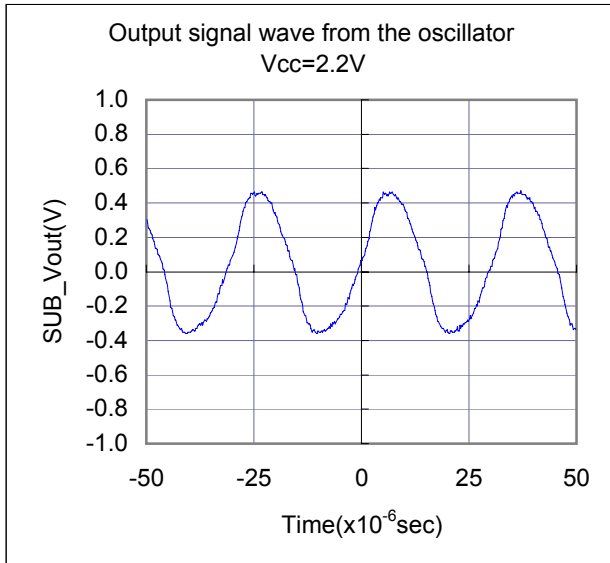

Evaluation of Low Frequency Clock Oscillation Circuit

SSP-T7 7.0pF with MB95107A-64P [LQFP(10x10) 0.50mm pitch]

Measurement conditions :3.0V , 2.2V



Test Data : Temperature characteristics

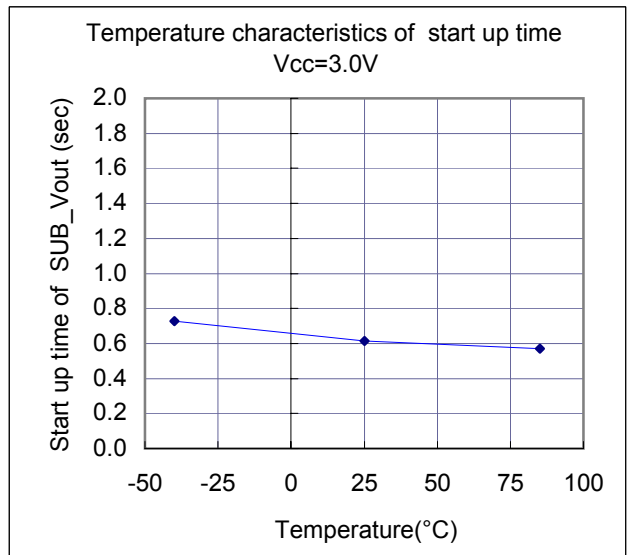
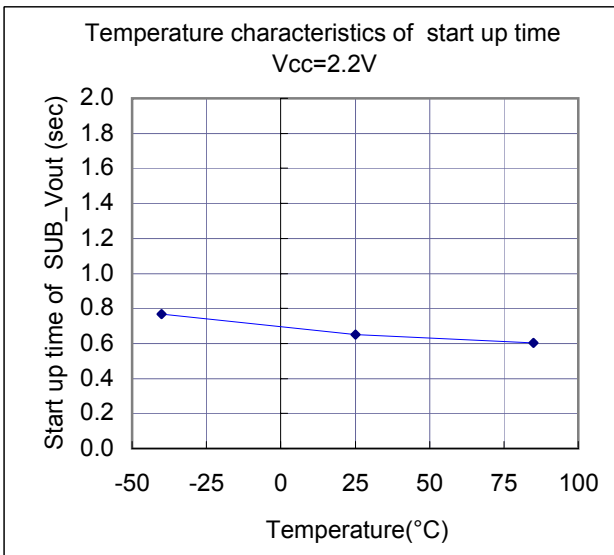
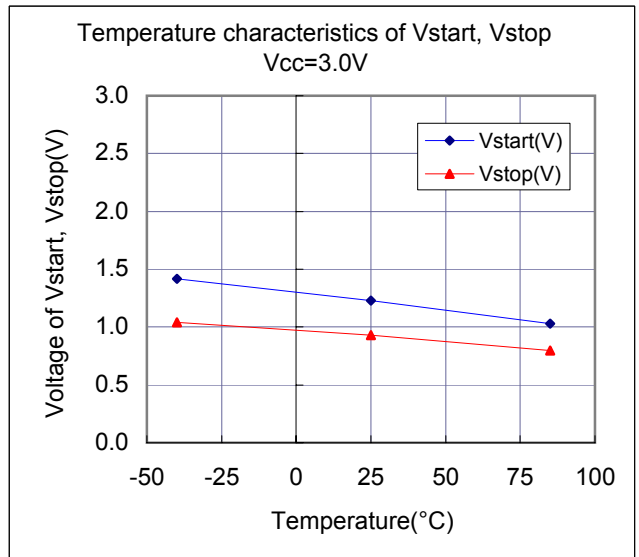
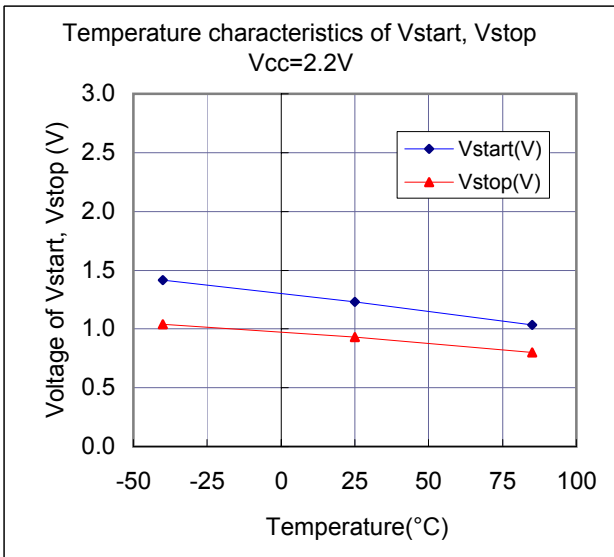
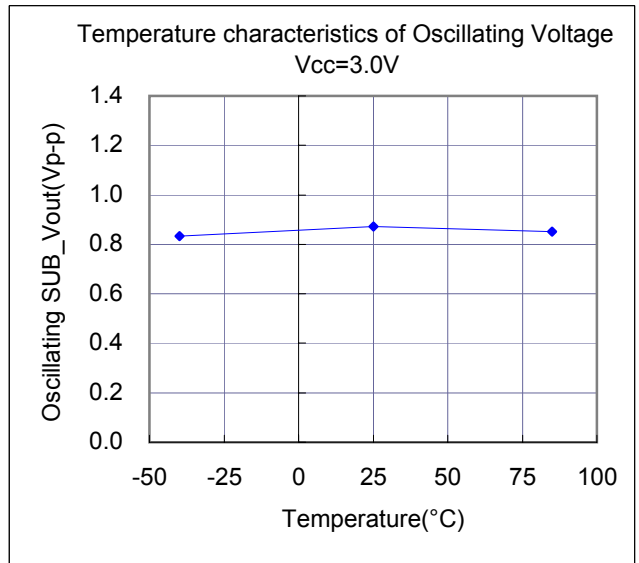
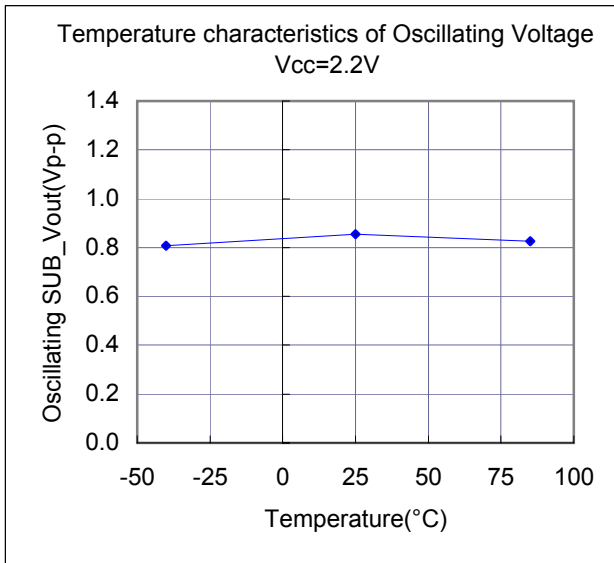

Evaluation of Low Frequency Clock Oscillation Circuit

SSP-T7 7.0pF with MB95107A-64P [LQFP(10x10) 0.50mm pitch]

Measurement conditions :3.0V , 2.2V



Referential components layout(see Figure 1)

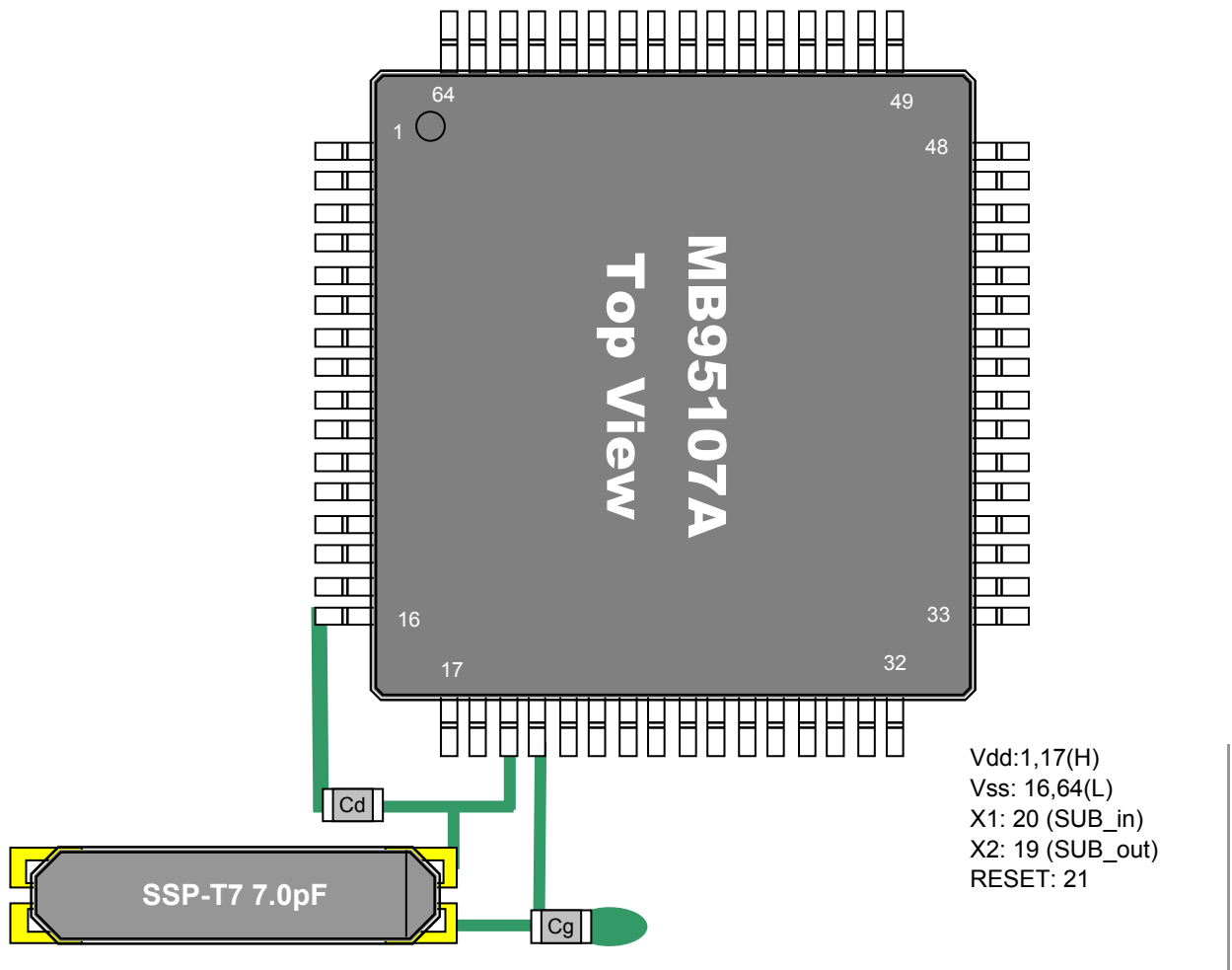

Figure 1 Referential components layout

Notes for Board Design

When using a crystal resonator, place the resonator and its load capacitors as close as possible to SUB_in and SUB_out pins.
 Other signal lines should be routed away from the resonator circuit to prevent induction from interfering with correct oscillation (see figure 2).

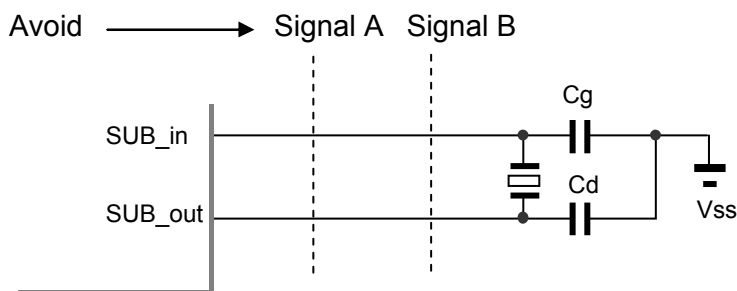

Figure 2 Example of Incorrect Board Design

Remark When using the subsystem clock, insert resistors Rd in series on the SUB_out side.

Evaluation of Low Frequency Clock Oscillation Circuit

SSP-T7 7.0pF with MB95107A-64P [LQFP(10x10) 0.50mm pitch]

Measurement conditions :3.0V , 2.2V



[Evaluation Sample at 25°C]

SAMPLE	No.	CL(pF)	Fo(Hz)	fr(Hz)	R1(kohm)	Co(pF)	C1(fF)	Q(k)
SSP-T7	1	7	32767.93	32763.77	41.8	0.86	1.995	58.3
	2	7	32767.88	32763.63	39.2	0.85	2.037	60.9
	3	7	32767.83	32763.68	40.3	0.83	1.983	60.8

[IC Test Data : IC samples Rd=0k ohm,Cg=8pF,Cd=8pF at 25°C]

Vcc(V)	IC sample	Fosc(Hz)	df / f(x10 ⁻⁶)	DL(x10 ⁻⁶ W)	-RL (kohm)	Vstart(V)	Ts(sec)
3.0	TYP_#1	32767.960	0.92	0.02	1653	1.23	0.62
	TYP_#2	32767.970	1.22	0.02	1653	1.24	0.60
2.2	TYP_#1	32767.918	-0.37	0.02	1553	1.23	0.65
	TYP_#2	32767.923	-0.21	0.02	1553	1.24	0.64

Remark (see figure 3)

$$F_o = f_r \times \{ C_1 / (2 \times (C_o + C_L)) + 1 \} \text{ (Hz)}$$

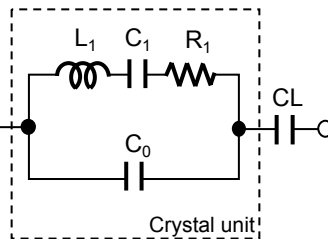

- Fo : Load resonance frequency
- fr : Resonance frequency
- R1 : Motional resistance
- C1 : Motional capacitance
- Co : Shunt capacitance
- CL : Load Capacitance

Figure 3 Equivalent circuit of crystal unit, and CL

Remark (see figure 4)

Approximate formula of the load capacitance of the circuit CL.

$$C_L = C_g \times C_d / (C_g + C_d) + C_s \text{ (pF)}$$

Where Cs(=2 to 4pF) Stands for stray capacitance of the circuit.

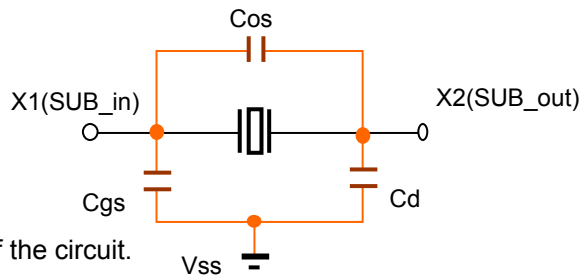

- Cos : X1_X2 Stray capacitance
- Cgs : X1_Vss Stray capacitance
- Cds : X2_Vss Stray capacitance

Figure 4 Stray capacitance Cos,Cgs,Cds of the circuit

Resonator circuit constants will differ depending on the resonator element, stray capacitance in its interconnecting circuit, and other factors. Suitable constants should be determined in consultation with the resonator element manufacturer.

Evaluation of Low Frequency Clock Oscillation Circuit

SSP-T7 7.0pF with MB95107A-64P [LQFP(10x10) 0.50mm pitch]

Measurement conditions : Vdd=1.8V to 3.6V at 25°C



Referential Data : Voltage characteristics

