

**Evaluation of a Low Frequency Clock Oscillation Circuit**

VT-200-FL 4.4pF with uPD78F1009GB-16BT [LQFP(10x10) 0.50mm pitch]

Measurement conditions : 3.0V



**New**



Model	:VT-200-FL
Frequency	:Fo=32.768kHz
Frequency tolerance	:dF/Fo= +/-17x10 <sup>-6</sup>
Load capacitance	:CL=4.4pF
Equivalent series resistance	:R1=50kΩ max
Max. drive level	:DL=1μW max
Level of drive	:DL=0.01μW typ

**FEATURES**

- 1.Compact tubular package
- 2.Photolithographic process
- 3.Excellent shock resistance and environmental characteristics.
- 4.Real time clocks, Timers, Portable applications

**DIMENSIONS(VT-200)**

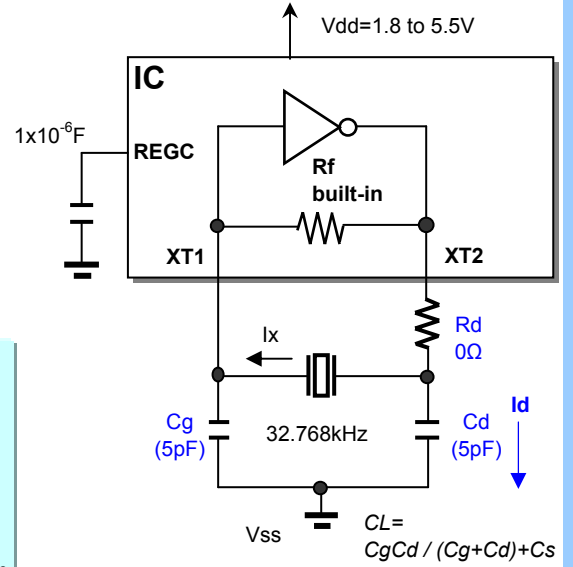
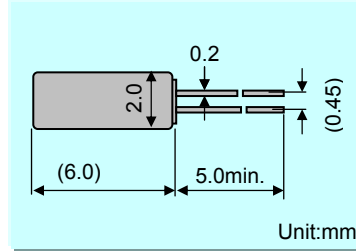

Remark) Ix : current through crystal

**Extremely low power consumption 78K0R/Kx3-L and VT-200-FL 4.4pF**

\*1 ; Low current consumption mode (default)

\*2 ; Extremely low current consumption mode

MODEL:VT-200-FL 4.4pF with uPD78F1009GB at 25°C

Key specifications	Low(*2)	Low(*1)	Remarks
Current control resistance : Rd ( kΩ )	0	0	Control drive level & secure phase margin
Capacitance at gate : Cg ( pF )	5	5	Optimal capacitance in response to CL
Capacitance at drain : Cd ( pF )	5	5	( CL = Cd // Cg + stray capacitance )

Circuit characteristics ( at 25°C )	Low(*2)	Low(*1)	Remarks
Matching Accuracy : df / f ( x10 <sup>-6</sup> )	1.6	2.5	Frequency offset volume at specified Vdd
Voltage Fluctuation : +/-df / V ( x10 <sup>-6</sup> )	0.0	0.0	Vdd +/-10% ( Standard operating voltage range )
Drive Level : DL ( μ W )	0.006	0.007	DL=Ix <sup>2</sup> Re < 1x10 <sup>-6</sup> W, Re=R1( 1 + Co / CL ) <sup>2</sup>
Negative resistance :   - RL   ( kΩ )	737	1057	5 times larger than R <sub>1MAX</sub>
Oscillation allowance : M ( times )	15	21	Judgmental standard of oscillation stability
<b>Low current consumption : Id (nA)</b>	<b>100</b>	<b>173</b>	Cd charge current, Id = ωCd*Vd < 200nA
Voltage of oscillation start : Vstart ( V )	1.63	1.63	
Voltage of oscillation stop : Vstop ( V )	1.59	1.59	
Oscillation start up time : Ts ( sec )	0.82	0.53	Time to reach 90% of output level<2.0sec

Temperature characteristics of circuit		Low(*2)	Low(*1)	Remarks
at -40°C	Variation : df / T ( x10 <sup>-6</sup> )	-143	-143	Typ.Tp=25°C ( K = -3.5x10 <sup>-8</sup> / °C <sup>2</sup> )
at +85°C	Variation : df / T ( x10 <sup>-6</sup> )	-121	-121	Typ.Tp=25°C ( K = -3.5x10 <sup>-8</sup> / °C <sup>2</sup> )

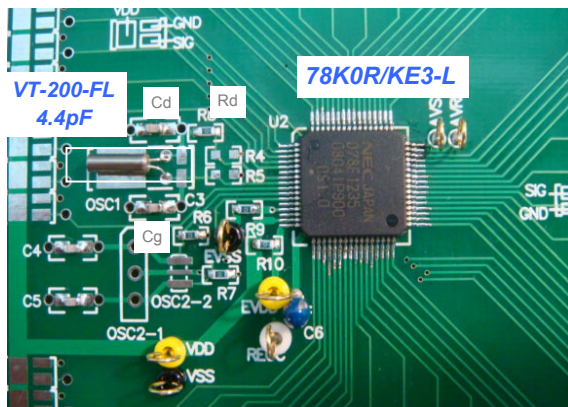

**Seiko Instruments USA Inc.**

2990,West Lomita Blvd., Torrance, CA 90505, U.S.A  
 Telephone :+1 310-517-7771 Facsimile :+1 310-517-7792  
 Email :info@siu-la.com

**Seiko Instruments GmbH**

Siemensstrasse 9,D-63263 Neu-Isenburg,Germany  
 Telephone :+49-6102-297-0 Facsimile :+49-6102-297-320  
 Email :info@seiko-instruments.de

**Seiko Instruments Inc.**

1-8,Nakase,Mihama-ku,Chiba-shi,Chiba 261-8507,Japan  
 Facsimile :+81-43-211-8030  
 E-mail :component@sii.co.jp

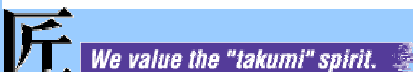

Seiko Instruments Inc.  
 Phone:+81-43-211-1207(Direct)

**Evaluation of a Low Frequency Clock Oscillation Circuit**

VT-200-FL 4.4pF with uPD78F1009GB-16BT [LQFP(10x10) 0.50mm pitch]

Measurement conditions : 3.0V



Test Data at 25°C

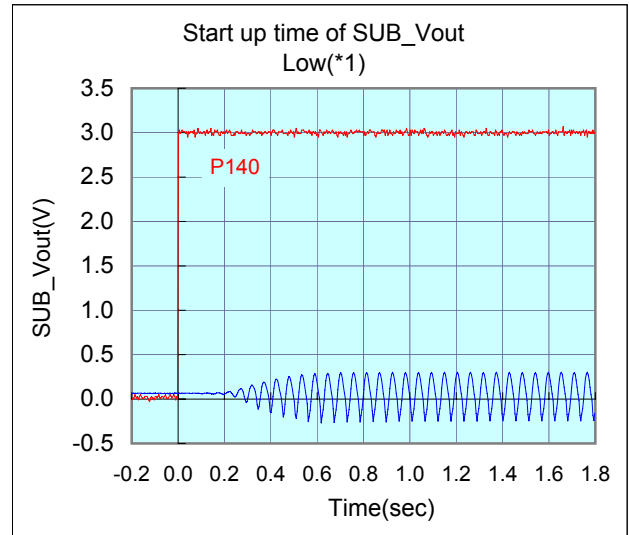
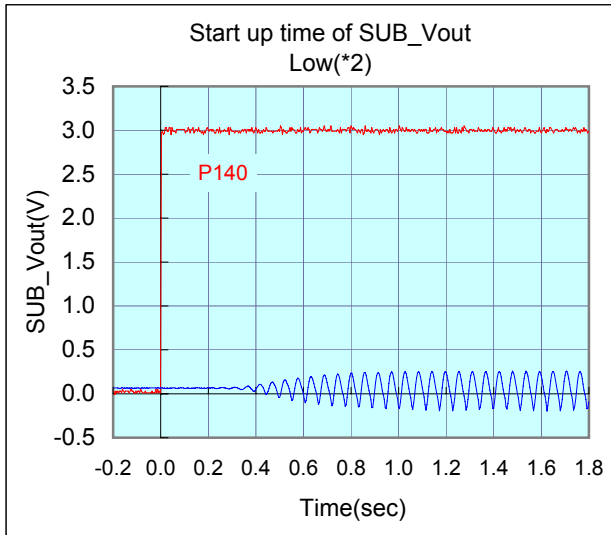
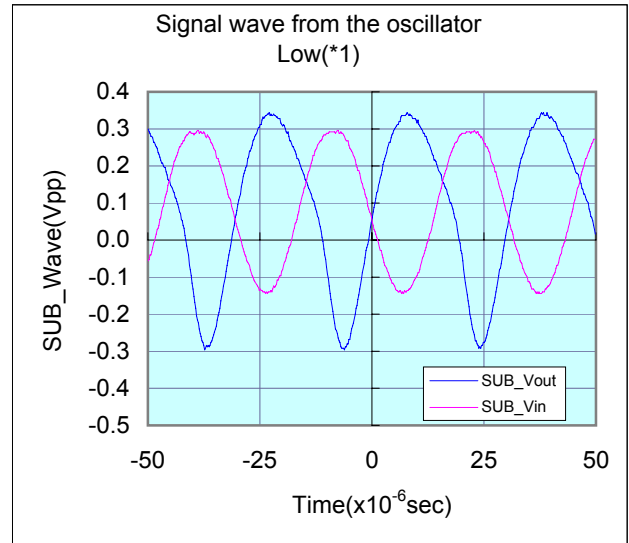
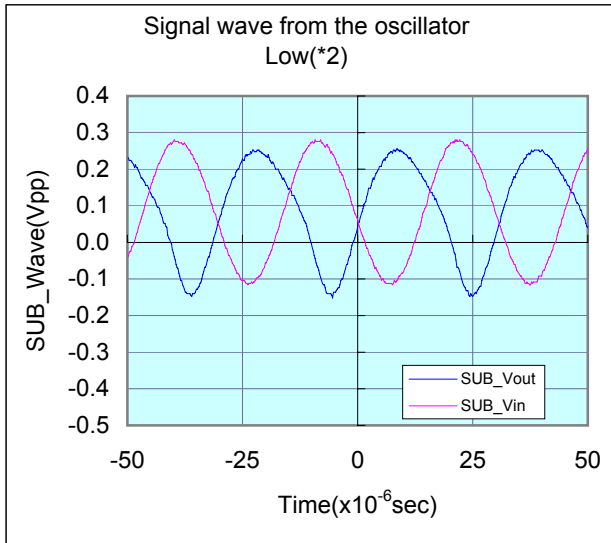

\*2 ; Extremely low current consumption mode

\*1 ; Low current consumption mode

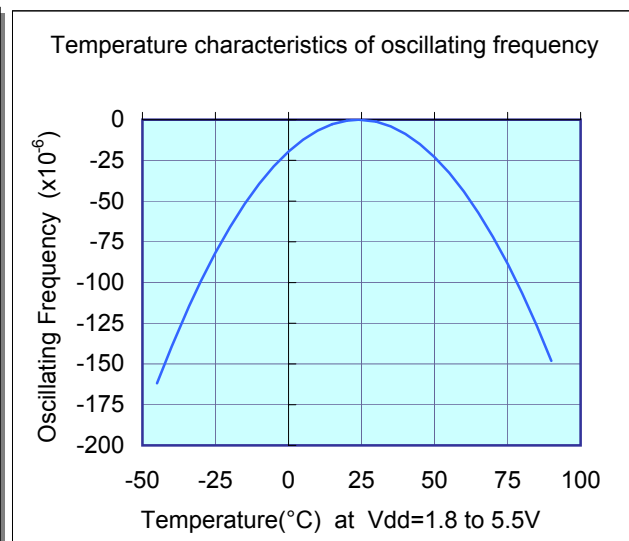
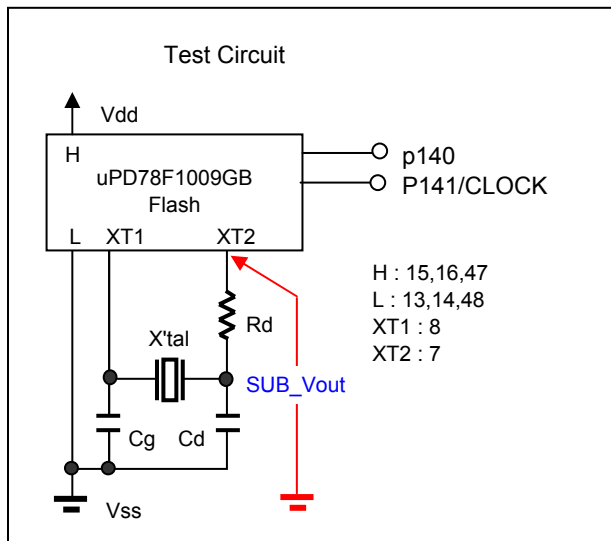

**Evaluation of a Low Frequency Clock Oscillation Circuit**

VT-200-FL 4.4pF with uPD78F1009GB-16BT [LQFP(10x10) 0.50mm pitch]

Measurement conditions : 3.0V



Test Data : Temperature characteristics

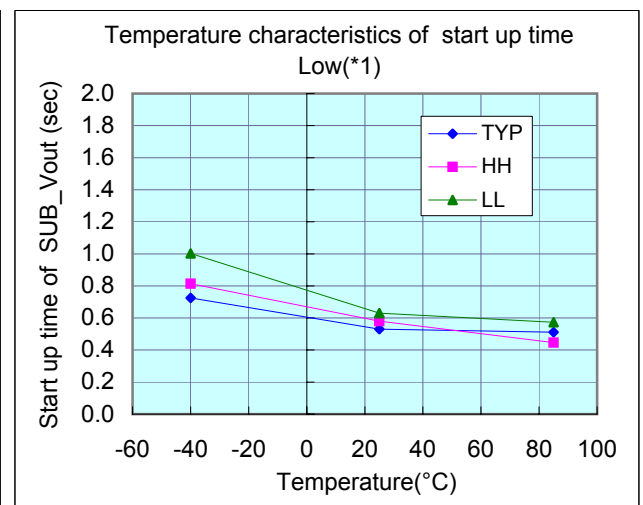
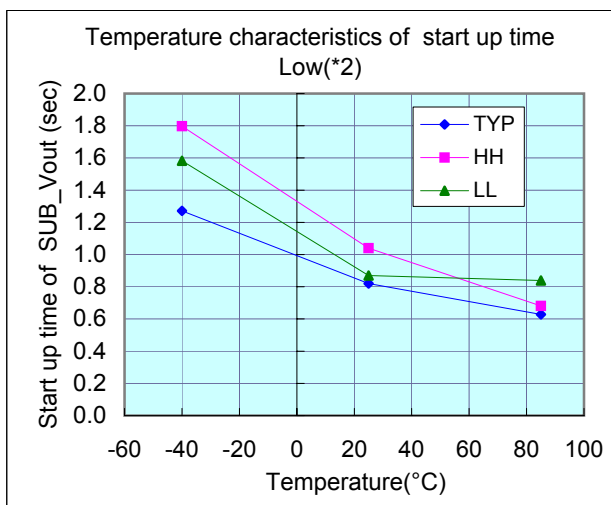
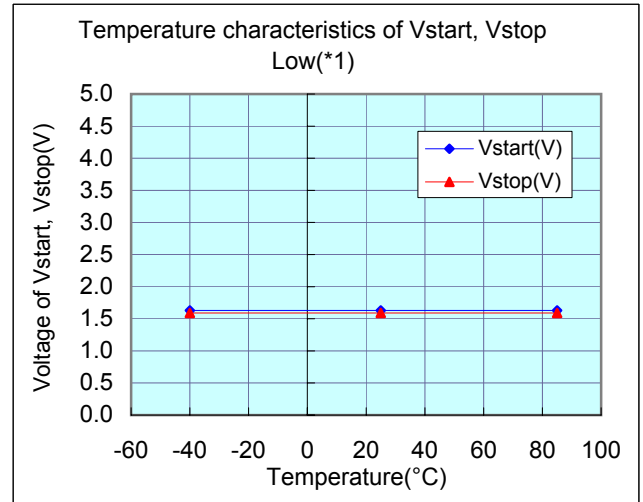
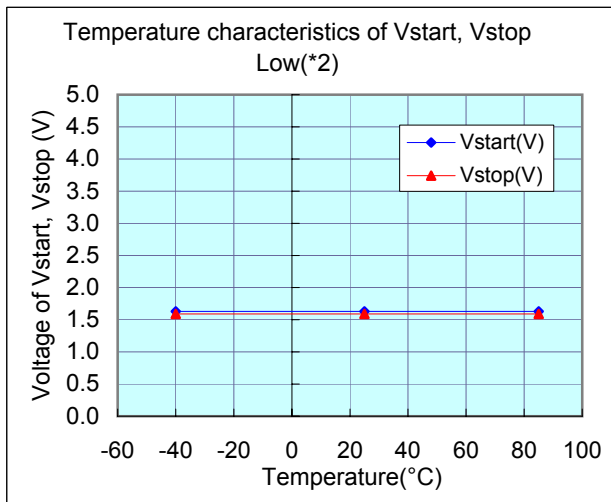
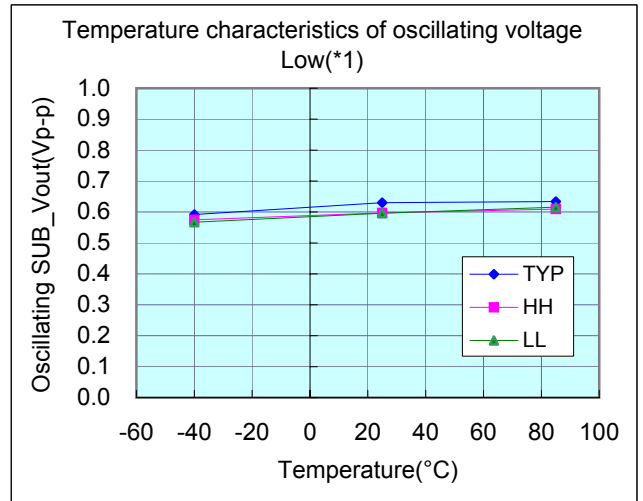
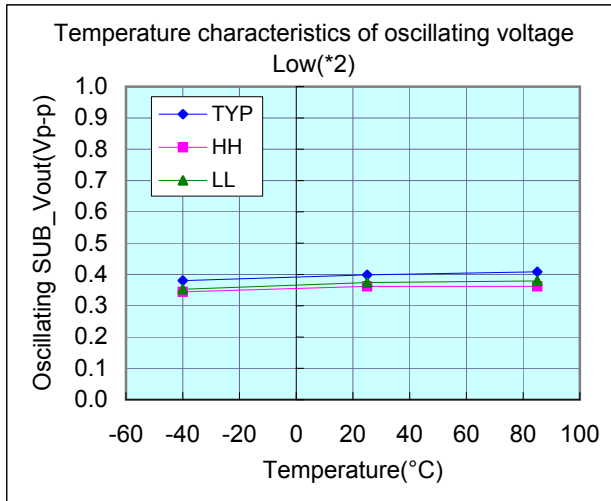

\*2 ; Extremely low current consumption mode

\*1 ; Low current consumption mode

The above mentioned value is only for your reference. The value is for the arbitrary samples and does not guarantee the product's characteristics. Please review and check above parameters at customer's end.

**Evaluation of a Low Frequency Clock Oscillation Circuit**

VT-200-FL 4.4pF with uPD78F1009GB-16BT [LQFP(10x10) 0.50mm pitch]

Measurement conditions : 3.0V



**Referential components layout(see Figure 1)**

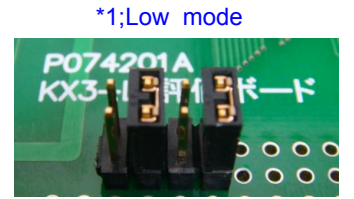
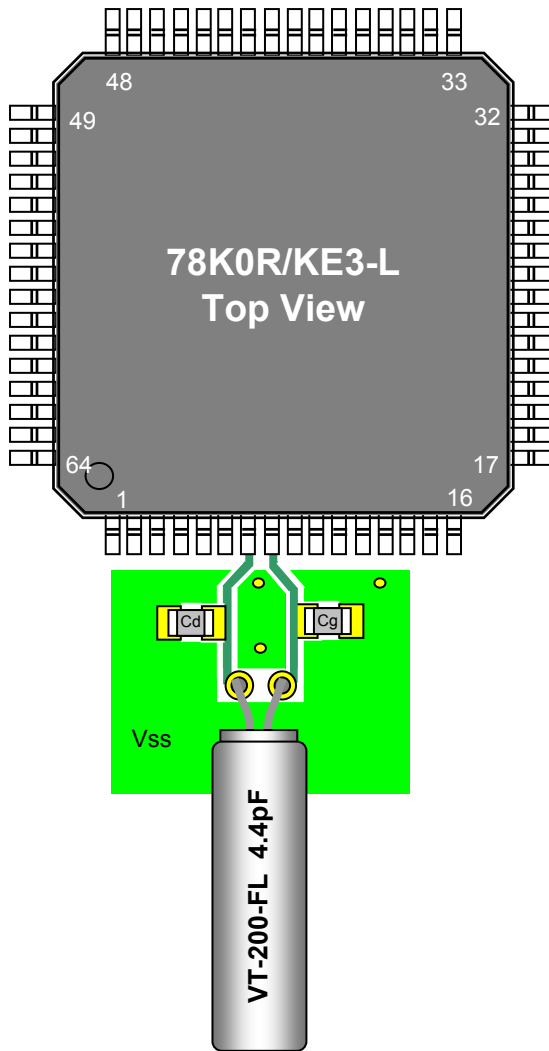

\*1;Low mode



\*2;Extremely Low mode

- Vdd:15 (H)
- EVdd:16(H)
- AVREF:47(H)
- AVss:48 (L)
- Vss:13(L)
- Evss:14(L)
- FLMD0:9(L)
- XT1:8 (SUB\_in)
- XT2:7 (SUB\_out)
- RESET:6
- REGC:12
- P140:64

**Figure 1 Referential components layout**

**Notes Board Design**

When using a crystal resonator, place the resonator and its load capacitors as close as possible to SUB\_in and SUB\_out pins.

Other signal lines should be routed away from the resonator circuit to prevent induction from interfering with correct oscillation (see figure 2).

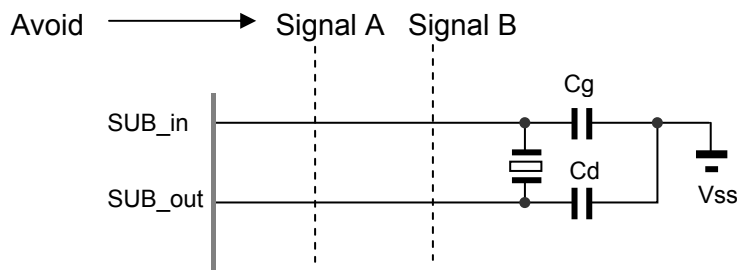

**Figure 2 Example of Incorrect Board Design**

**Remark** When using the subsystem clock, insert a resistor, Rd, in series on the SUB\_out side.

**Evaluation of a Low Frequency Clock Oscillation Circuit**

VT-200-FL 4.4pF with uPD78F1009GB-16BT [LQFP(10x10) 0.50mm pitch]

Measurement conditions : 3.0V

**[Evaluation Sample at 25°C]**

SAMPLE	No.	CL (pF)	Fo (Hz)	fr (Hz)	R1 (kΩ)	Co (pF)	C1 (fF)	Q (k)
VT-200-FL	1	4.4	32767.98	32761.57	38.1	0.88	2.066	61.7
	2	4.4	32767.96	32761.55	36.9	0.87	2.063	63.8
	3	4.4	32768.00	32761.53	38.6	0.88	2.086	60.4

**[IC Test Data : IC Sample Rd=0Ω,Cg=5pF,Cd=5pF at 25°C]**

Power mode	IC Sample	Fosc (Hz)	df / f (x10 <sup>-6</sup> )	DL(μW)	-RL  (kΩ)	M(times)	Id (nA)	Vstart (V)	Ts(sec)
Low(*1)	TYP	32768.08	2.50	0.007	1057	21	173	1.63	0.53
	HH	32768.08	2.47	0.010	1057	21	164	1.63	0.58
	LL	32768.03	0.98	0.006	967	19	165	1.63	0.63
	HL	32768.09	2.59	0.011	967	19	164	1.63	0.50
	LH	32768.10	3.05	0.006	1057	21	167	1.63	0.57

\*1; Low ccurrent onsumption mode

**[IC Test Data : IC Sample Rd=0Ω,Cg=5pF,Cd=5pF at 25°C]**

Power mode	IC Sample	Fosc (Hz)	df / f (x10 <sup>-6</sup> )	DL(μW)	-RL  (kΩ)	M(times)	Id (nA)	Vstart (V)	Ts(sec)
Low(*2)	TYP	32768.05	1.65	0.006	737	15	100	1.63	0.82
	HH	32768.02	0.52	0.005	737	15	91	1.63	1.04
	LL	32768.02	0.73	0.005	677	14	94	1.63	0.87
	HL	32768.04	1.19	0.006	617	12	93	1.63	1.09
	LH	32768.07	2.14	0.005	737	15	95	1.63	0.85

\*2; Extremely low current consumption mode

**Remark ( see figure 3 )**

$$F_o = f_r \times \{ C_1 / ( 2 \times ( C_o + C_L ) ) + 1 \} \quad (\text{Hz})$$

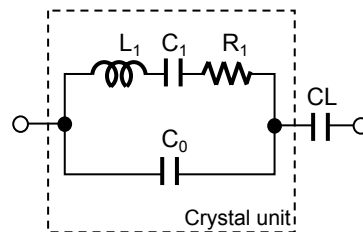

Fo : Load resonance frequency  
fr : Resonance frequency  
R1 : Motional resistance  
C1 : Motional capacitance  
Co : Shunt capacitance  
CL : Load Capacitance

**Figure 3 Equivalent circuit of crystal unit, and CL****Remark ( see figure 4 )**

Approximate formula of the load capacitance of the circuit CL,

$$C_L = C_g \times C_d / ( C_g + C_d ) + C_s \quad (\text{pF})$$

$$C_s = C_{gs} \times C_{ds} / ( C_{gs} + C_{ds} ) + C_{os} \quad (\text{pF})$$

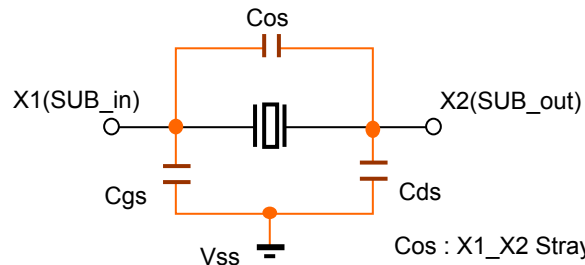

Cos : X1\_X2 Stray capacitance  
Cgs : X1\_Vss Stray capacitance  
Cds : X2\_Vss Stray capacitance

where Cs(=1.5 to 2.5pF) stands for stray capacitance of the circuit.

**Figure 4 Stray capacitance Cos,Cgs,Cds of the circuit**

Resonator circuit constants differ depending on the resonator element, stray capacitance in its interconnecting circuit, and other factors. Suitable constants should be determined in consultation with the resonator element manufacturer.



**Evaluation of a Low Frequency Clock Oscillation Circuit**

VT-200-FL 4.4pF with uPD78F1009GB-16BT [LQFP(10x10) 0.50mm pitch]

Measurement conditions : Vdd=1.8V to (6.0)V at 25°C



Referential Data(1): Voltage characteristics

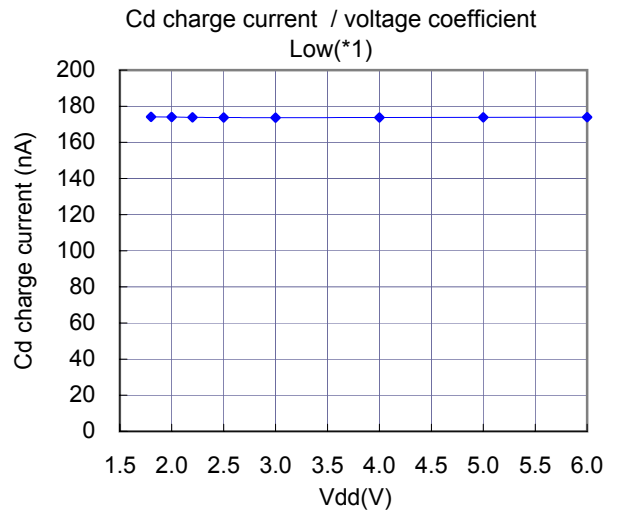
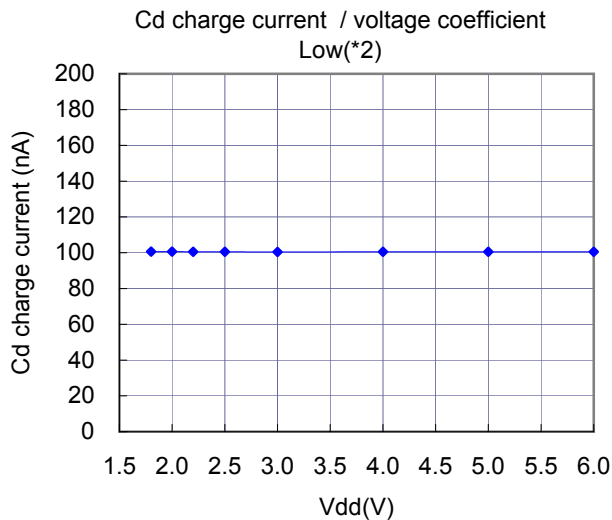
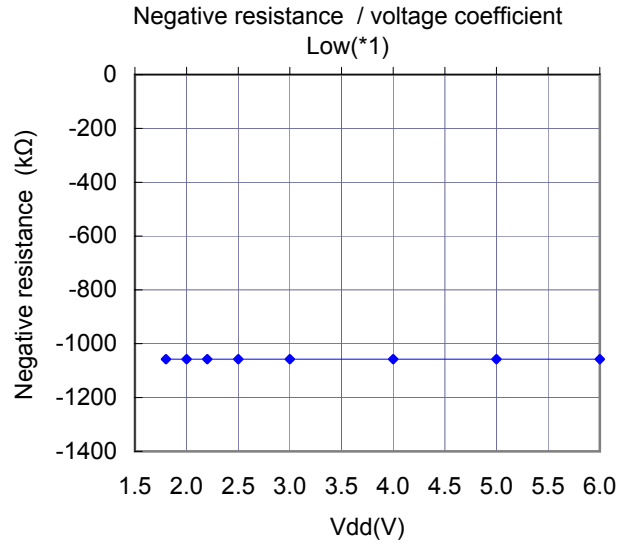
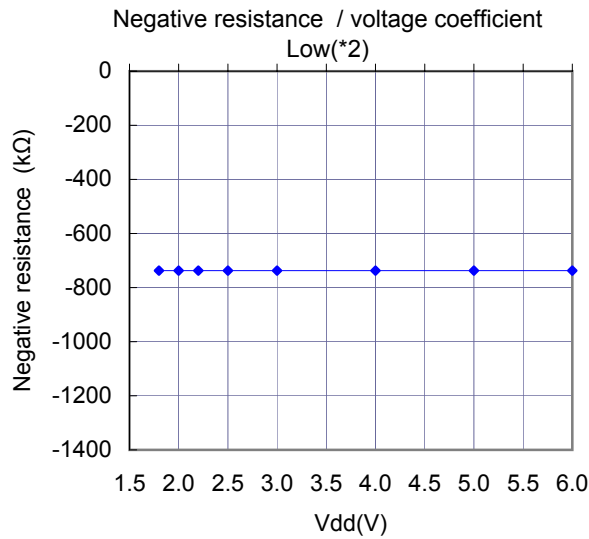
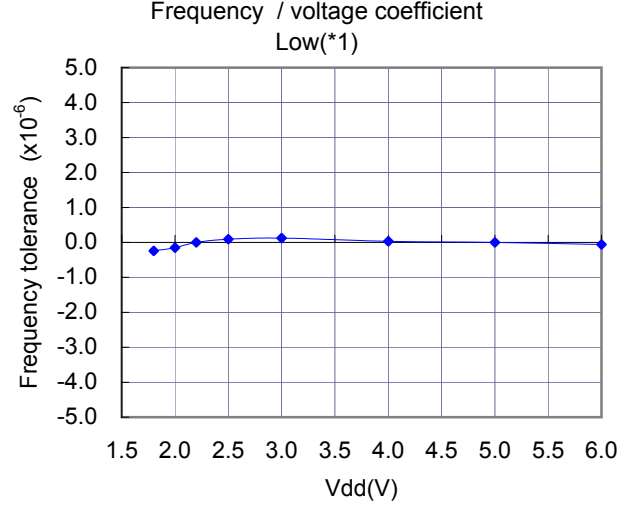
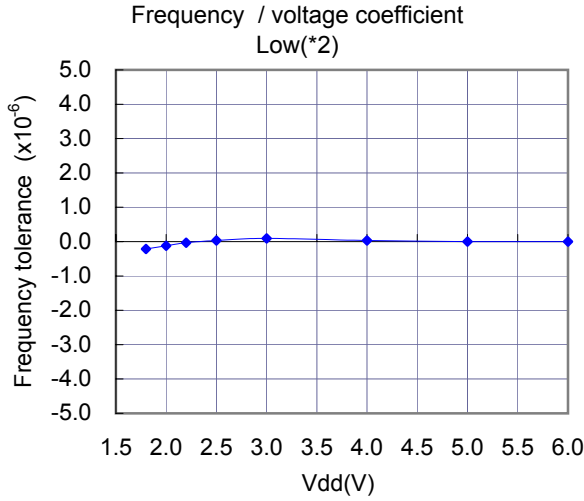

\*2 ; Extremely low current consumption mode

\*1 ; Low current consumption mode

**Evaluation of a Low Frequency Clock Oscillation Circuit**

VT-200-FL 4.4pF with uPD78F1009GB-16BT [LQFP(10x10) 0.50mm pitch]

Measurement conditions : Vdd=1.8V to 5.5V at 25°C



Referential Data(2) : External capacitance Cg,Cd characteristics

Circuit capacitance CL / external Cg,Cd coefficient

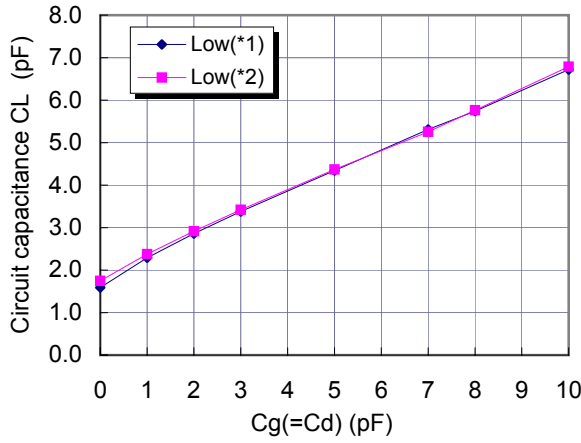

SUB\_Vout / external Cg,Cd coefficient

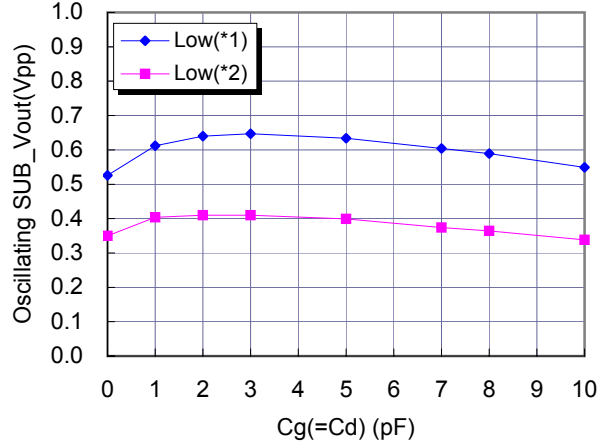

Negative resistance / external Cg,Cd coefficient

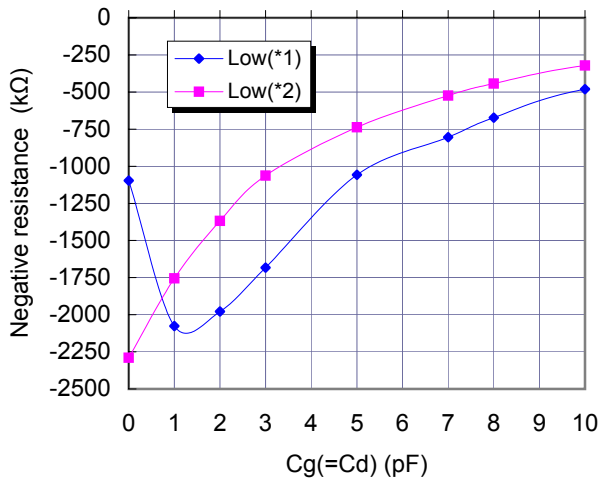

Drive level / external Cg,Cd coefficient

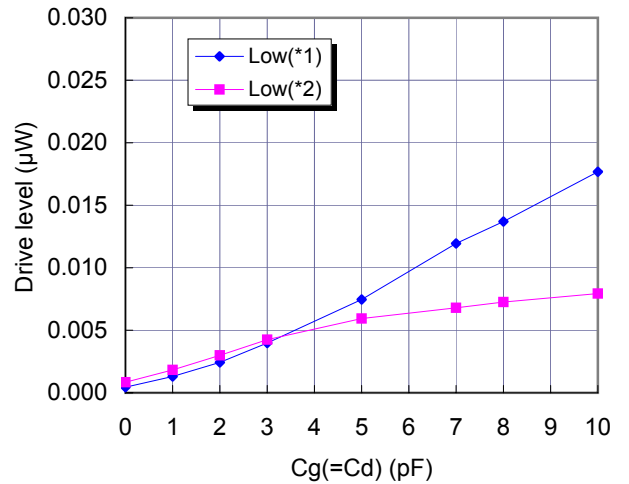

Cd charge current / external Cg,Cd coefficient

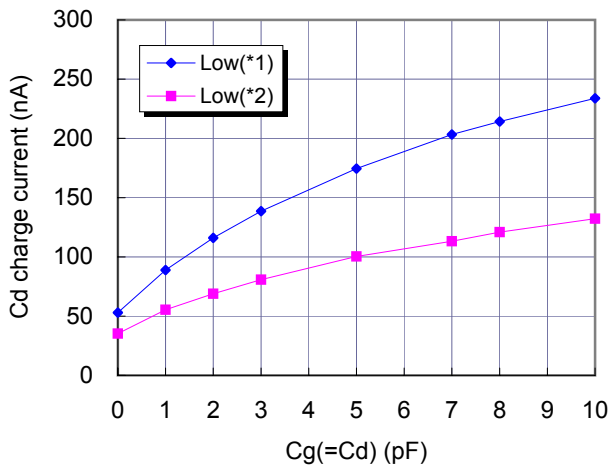

Start up time / external Cg,Cd coefficient

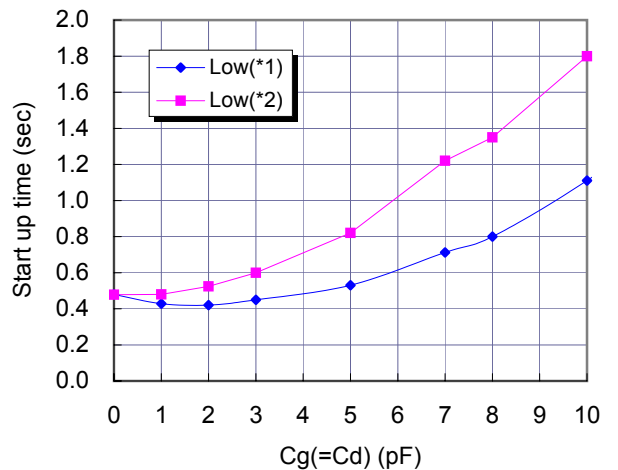

**Evaluation of a Low Frequency Clock Oscillation Circuit**

VT-200-FL 4.4pF with uPD78F1009GB-16BT [LQFP(10x10) 0.50mm pitch]

Measurement conditions : Vdd=1.8V to 5.5V at 25°C



Referential Data(3) : External capacitance Cg,Cd characteristics

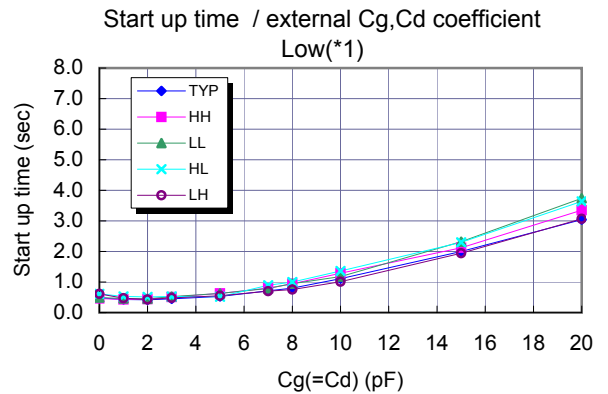
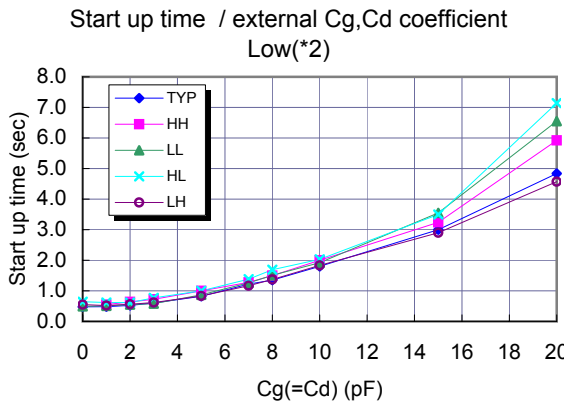
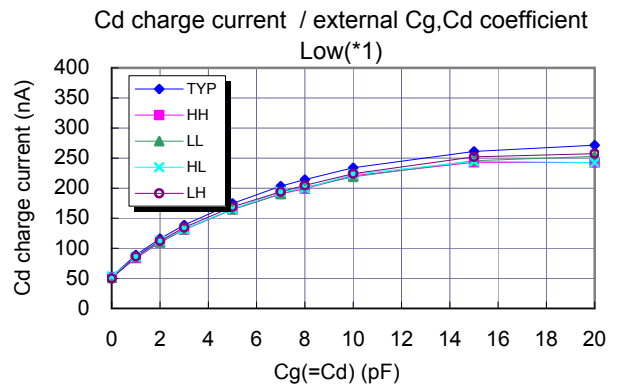
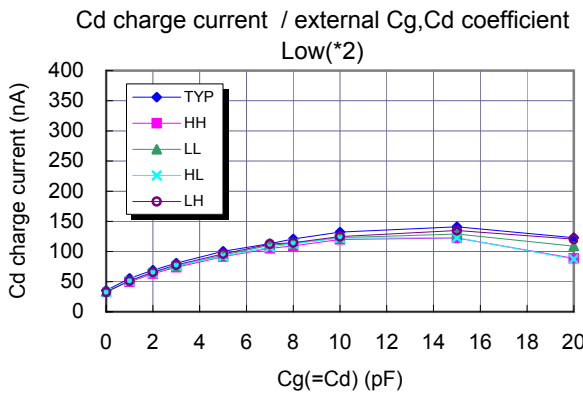
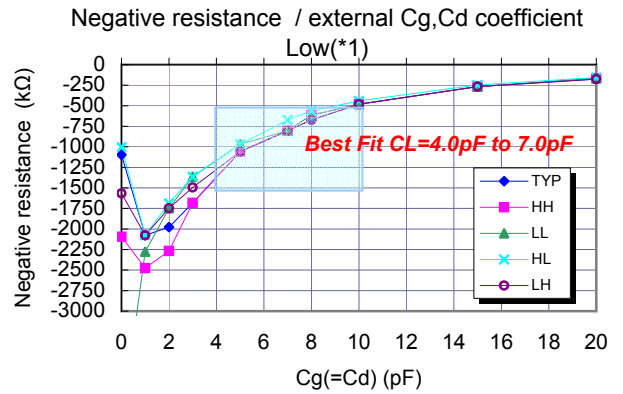
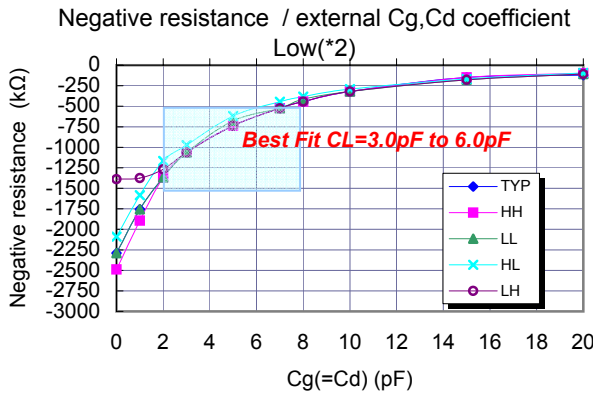
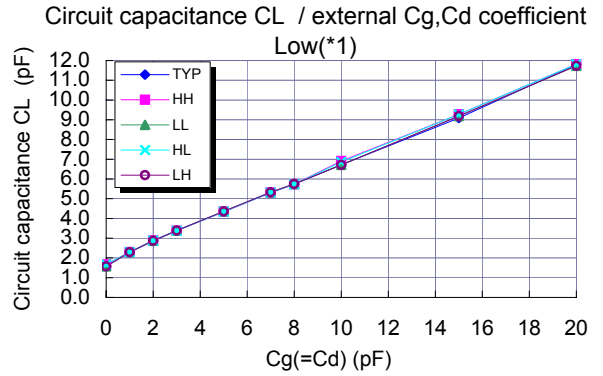
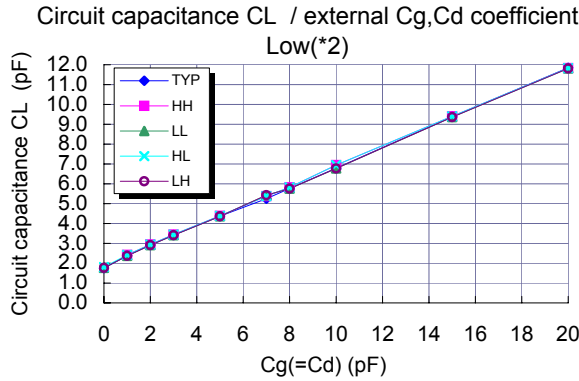

\*2 ; Extremely low current consumption mode

\*1 ; Low current consumption mode

**Evaluation of a Low Frequency Clock Oscillation Circuit**

VT-200-FL 4.4pF with uPD78F1009GB-16BT [LQFP(10x10) 0.50mm pitch]

Measurement conditions : Vdd=1.8V to 5.5V at 25°C



Referential Data(4) : Signal wave from oscillator(HH,HL,LH,LL)

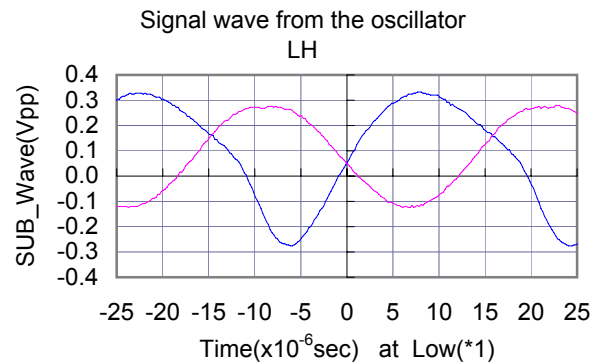
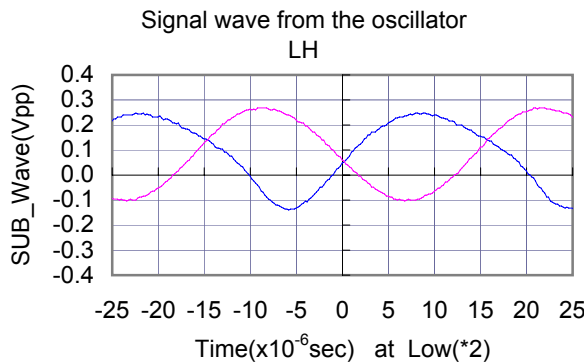
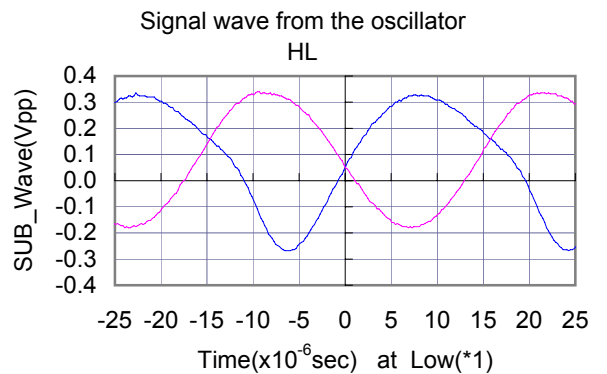
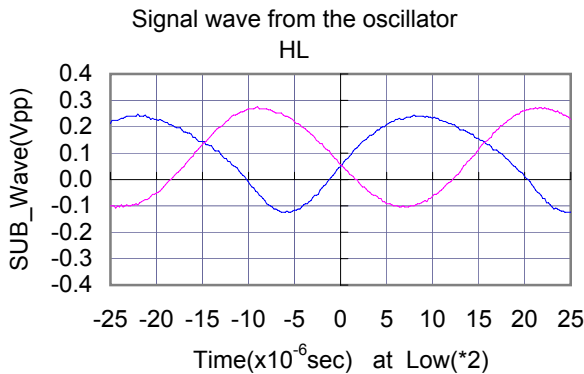
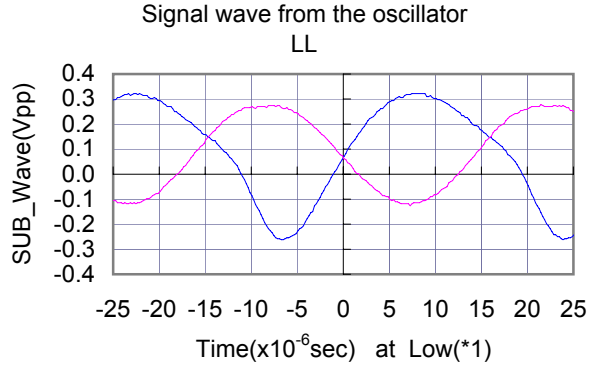
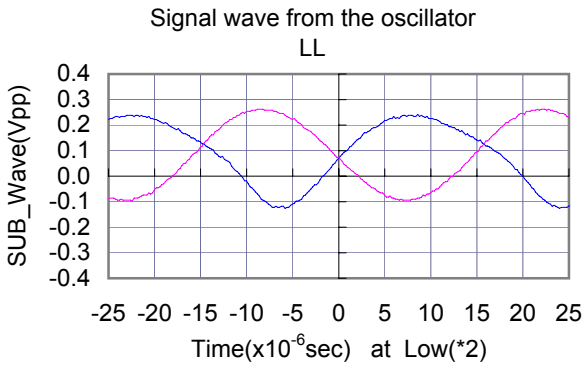
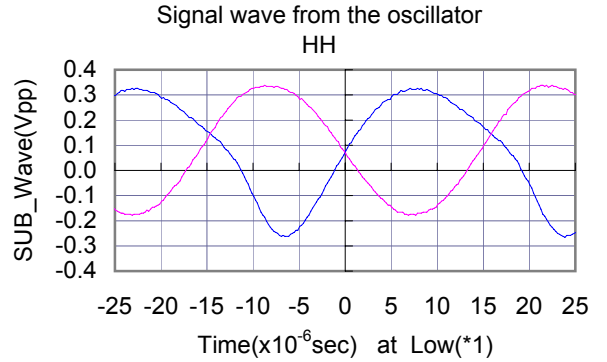
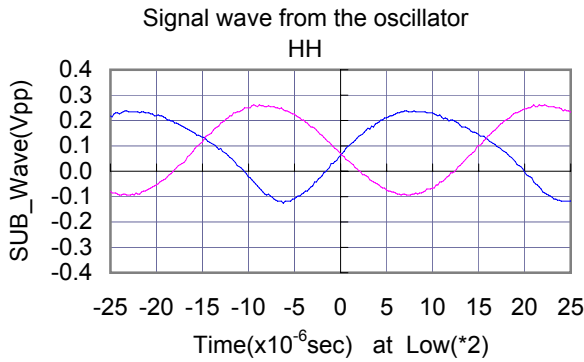

*\*2 ; Extremely low current consumption mode*

*\*1 ; Low current consumption mode*

**Evaluation of a Low Frequency Clock Oscillation Circuit**

VT-200-FL 4.4pF with uPD78F1009GB-16BT [LQFP(10x10) 0.50mm pitch]

Measurement conditions : V<sub>DD</sub>=1.8V to 5.5V at 25°C

## Referential Data(5) : Negative resistance (RL) &amp; Oscillation allowance (M)\_Map

Negative resistance RL(KΩ) at 25°C

TYP_Cg,Cd	Low(*2)	Low(*1)	Normal	CL(pF)
20	121	176	286	11.8
15	148	268	478	9.1
10	321	481	801	6.7
8	443	673	1053	5.7
5	738	1058	1878	4.3
2	1368	1978	2268	2.9
0	2296	1096	0	1.6

Oscillation allowance M (= RL / R<sub>1max</sub>) at 25°C

TYP_Cg,Cd	Low(*2)	Low(*1)	Normal	CL(pF)
20	2	4	6	11.8
15	3	5	10	9.1
10	6	10	16	6.7
8	9	13	21	5.7
5	15	21	38	4.3
2	27	40	45	2.9
0	46	22	0	1.6

\* R<sub>1max</sub>=50kΩ

Negative resistance RL(KΩ) at 25°C

HH_Cg,Cd	Low(*2)	Low(*1)	Normal	CL(pF)
20	97	166	266	11.8
15	148	268	438	9.3
10	321	481	801	6.9
8	443	613	1153	5.7
5	738	1058	2058	4.3
2	1368	2268	3568	2.9
0	2493	2093	0	1.7

Oscillation allowance M (= RL / R<sub>1max</sub>) at 25°C

HH_Cg,Cd	Low(*2)	Low(*1)	Normal	CL(pF)
20	2	3	5	11.8
15	3	5	9	9.3
10	6	10	16	6.9
8	9	12	23	5.7
5	15	21	41	4.3
2	27	45	71	2.9
0	50	42	0	1.7

\* R<sub>1max</sub>=50kΩ

Negative resistance RL(KΩ) at 25°C

LL_Cg,Cd	Low(*2)	Low(*1)	Normal	CL(pF)
20	108	166	266	11.7
15	178	268	438	9.2
10	321	481	671	6.7
8	413	613	803	5.7
5	678	968	1058	4.4
2	1368	1748	1888	2.9
0	2297	4397	0	1.6

Oscillation allowance M (= RL / R<sub>1max</sub>) at 25°C

LL_Cg,Cd	Low(*2)	Low(*1)	Normal	CL(pF)
20	2	3	5	11.7
15	4	5	9	9.2
10	6	10	13	6.7
8	8	12	16	5.7
5	14	19	21	4.4
2	27	35	38	2.9
0	46	88	0	1.6

\* R<sub>1max</sub>=50kΩ

Negative resistance RL(KΩ) at 25°C

HL_Cg,Cd	Low(*2)	Low(*1)	Normal	CL(pF)
20	93	156	246	11.8
15	168	248	408	9.3
10	291	441	731	6.9
8	383	563	963	5.7
5	618	968	1488	4.3
2	1168	1688	2668	2.9
0	2093	1003	0	1.7

Oscillation allowance M (= RL / R<sub>1max</sub>) at 25°C

HL_Cg,Cd	Low(*2)	Low(*1)	Normal	CL(pF)
20	2	3	5	11.8
15	3	5	8	9.3
10	6	9	15	6.9
8	8	11	19	5.7
5	12	19	30	4.3
2	23	34	53	2.9
0	42	20	0	1.7

\* R<sub>1max</sub>=50kΩ

Negative resistance RL(KΩ) at 25°C

LH_Cg,Cd	Low(*2)	Low(*1)	Normal	CL(pF)
20	108	176	286	11.7
15	178	268	478	9.2
10	321	481	801	6.7
8	443	673	1053	5.7
5	738	1058	1568	4.4
2	1268	1748	2668	2.9
0	1397	1567	0	1.6

Oscillation allowance M (= RL / R<sub>1max</sub>) at 25°C

LH_Cg,Cd	Low(*2)	Low(*1)	Normal	CL(pF)
20	2	4	6	11.7
15	4	5	10	9.2
10	6	10	16	6.7
8	9	13	21	5.7
5	15	21	31	4.4
2	25	35	53	2.9
0	28	31	0	1.6

\* R<sub>1max</sub>=50kΩ

**Evaluation of a Low Frequency Clock Oscillation Circuit**

VT-200-FL 4.4pF with uPD78F1009GB-16BT [LQFP(10x10) 0.50mm pitch]

Measurement conditions : Vdd=1.8V to 5.5V



Referential Data(6) : Circuit characteristics (TYP,HH,LL) at -40°C / +85°C

at -40°C

Circuit characteristics (TYP)	Low(*2)	Low(*1)
Negative resistance :   - RL   ( kΩ )	617	877
Oscillation allowance: M( times )	12	18
Oscillation start up time: Ts( sec )	1.27	0.72

\*1; Low current consumption mode (M=21 at 25°C)  
 \*2; Extremely low current consumption mode (M=15 at 25°C)

at 85°C

Circuit characteristics (TYP)	Low(*2)	Low(*1)
Negative resistance :   - RL   ( kΩ )	877	1057
Oscillation allowance: M( times )	18	21
Oscillation start up time: Ts( sec )	0.63	0.51

\*1; Low current consumption mode (M=21 at 25°C)  
 \*2; Extremely low current consumption mode (M=15 at 25°C)

at -40°C

Circuit characteristics (HH)	Low(*2)	Low(*1)
Negative resistance :   - RL   ( kΩ )	617	877
Oscillation allowance: M( times )	12	18
Oscillation start up time: Ts( sec )	1.80	0.81

\*1; Low current consumption mode (M=21 at 25°C)  
 \*2; Extremely low current consumption mode (M=15 at 25°C)

at 85°C

Circuit characteristics (HH)	Low(*2)	Low(*1)
Negative resistance :   - RL   ( kΩ )	877	1487
Oscillation allowance: M( times )	18	30
Oscillation start up time: Ts( sec )	0.68	0.45

\*1; Low current consumption mode (M=21 at 25°C)  
 \*2; Extremely low current consumption mode (M=15 at 25°C)

at -40°C

Circuit characteristics (LL)	Low(*2)	Low(*1)
Negative resistance :   - RL   ( kΩ )	567	807
Oscillation allowance: M( times )	11	16
Oscillation start up time: Ts( sec )	1.58	1.00

\*1; Low current consumption mode (M=19 at 25°C)  
 \*2; Extremely low current consumption mode (M=14 at 25°C)

at 85°C

Circuit characteristics (LL)	Low(*2)	Low(*1)
Negative resistance :   - RL   ( kΩ )	807	967
Oscillation allowance: M( times )	16	19
Oscillation start up time: Ts( sec )	0.84	0.57

\*1; Low current consumption mode (M=19 at 25°C)  
 \*2; Extremely low current consumption mode (M=14 at 25°C)

**Extremely low power consumption of 1/10 : 78K0R/Kx3-L & Low CL series**

\* It is achieved by the technical collaboration to make low AMP and low CL Tuning Fork.

**NEC MPU 78K0R/Kx3-L series**  
 78K0R/KC3-L;uPD78F1000MC/1001MC/1002MC/1003MC  
 uPD78F1000GA/1001GA/1002GA/1003GA  
 uPD78F1000GB/1001GB/1002GB/1003GB  
 78K0R/KD3-L;uPDF1004GB/1005GB/1006GB  
 78K0R/KE3-L;uPD78F1007GA/1008GA/1009GA  
 uPD78F1007GB/1008GB/1009GB  
 uPD78F1007GK/1008GK/1009GK

Normal current consumption <500nA

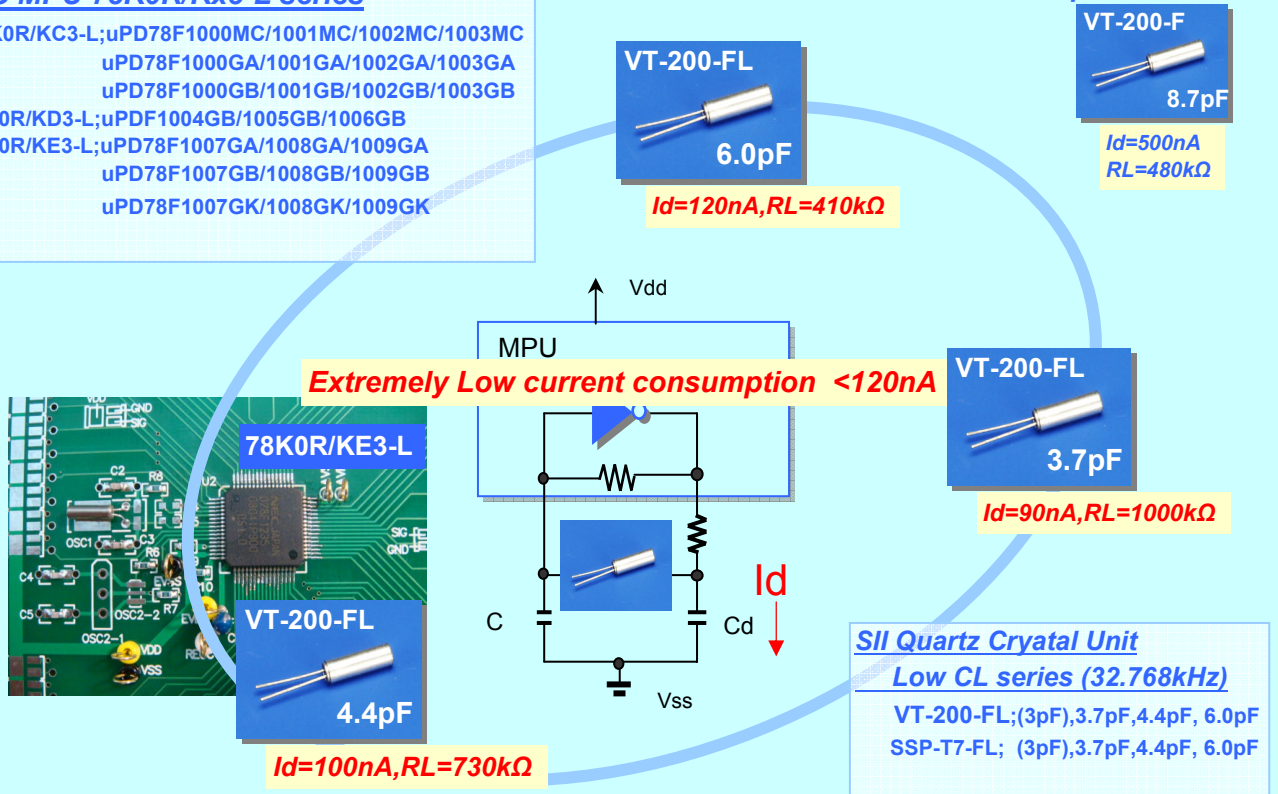

**SII Quartz Crystal Unit**  
 Low CL series (32.768kHz)  
 VT-200-FL; (3pF), 3.7pF, 4.4pF, 6.0pF  
 SSP-T7-FL; (3pF), 3.7pF, 4.4pF, 6.0pF