

**Evaluation of a Low Frequency Clock Oscillation Circuit**

SSP-T7-FL 6.0pF with uPD78F1014GC-16BT [LQFP(14x14) 0.5mm pitch]

Measurement conditions : 3.0V



**New**

**SSP-T7-FL**



**CL=6.0pF**

Model :SSP-T7-FL  
 Frequency :Fo=32.768kHz  
 Frequency tolerance :dF/Fo= +/-20x10<sup>6</sup>  
 Load capacitance :CL=6.0pF  
 Equivalent series resistance :R1=65kΩ max  
 Max. drive level :DL=1μW max  
 Level of drive :DL=0.01μW typ

**FEATURES**

- 1.Ultra thin type with 1.4mm Max.
- 2.SMD type suitable for automatic & high density surface mounting.
- 3.Plastic mold package containing highly reliable tubular type quartz crystal.
- 4.Excellent shock and heat resistance.
- 5.Cellular phones,PDA, Radio communication equipment, Portable applications etc.

**RECOMMENDED SOLDERING PATTERN**

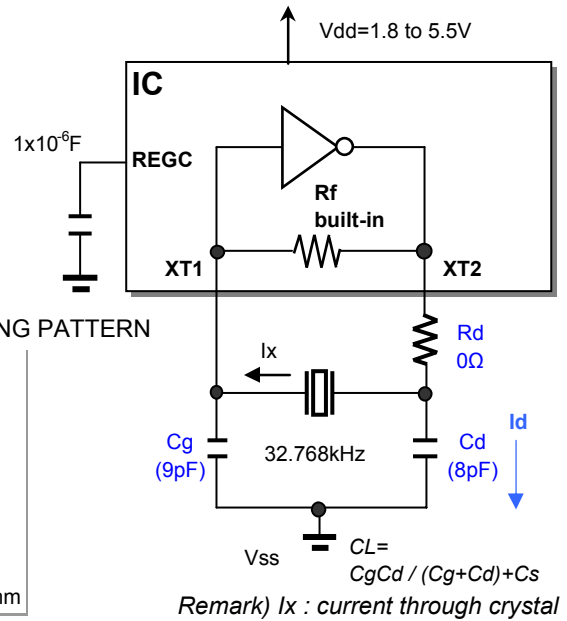
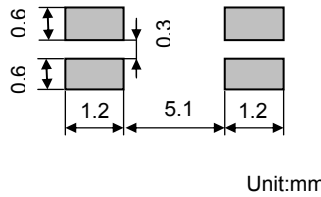

	REGVDD	Oscillation mode
Mode 1	2.4V	Low (*1)
Mode 2	1.8V	

Low power consumption 78K0R/Kx3-L and SSP-T7-FL 6.0pF

\*1 ; Low current consumption mode

MODEL:SSP-T7-FL 6.0pF with uPD78F1014GC at 25°C

Key specifications	mode 2	mode 1	Remarks
Current control resistance : Rd ( kΩ )	0	0	Control drive level & secure phase margin
Capacitance at gate : Cg ( pF )	9	9	Optimal capacitance in response to CL
Capacitance at drain : Cd ( pF )	8	8	( CL = Cd // Cg + stray capacitance )

Circuit characteristics ( at 25°C )	mode 2	mode 1	Remarks
Matching Accuracy : df / f ( x10 <sup>-6</sup> )	1.4	1.6	Frequency offset volume at specified Vdd
Voltage Fluctuation : +/-df / V ( x10 <sup>-6</sup> )	0.0	0.0	Vdd +/-10% ( Standard operating voltage range )
Drive Level : DL ( μW )	0.02	0.02	DL=Ix <sup>2</sup> Re < 1x10 <sup>-6</sup> W, Re=R1( 1 + Co / CL ) <sup>2</sup>
Negative resistance :   - RL   ( kΩ )	524	524	5 times larger than R <sub>1MAX</sub>
Oscillation allowance : M ( times )	8	8	Judgmental standard of oscillation stability
<b>Low current consumption : Id (nA)</b>	<b>208</b>	<b>207</b>	<b>Cd charge current, Id = ωCd*Vd &lt; 250nA</b>
Voltage of oscillation start : Vstrat ( V )	1.72	1.61	
Voltage of oscillation stop : Vstop ( V )	1.59	1.59	
Oscillation start up time : Ts ( sec )	1.05	1.05	Time to reach 90% of output level, Ts < 2.0sec

Temperature characteristics of circuit		mode 2	mode 1	Remarks
at -40°C	Variation : df / T ( x10 <sup>-6</sup> )	-138	-138	Typ.Tp=25°C ( K = -3.5x10 <sup>-8</sup> / °C <sup>2</sup> )
at +85°C	Variation : df / T ( x10 <sup>-6</sup> )	-129	-129	Typ.Tp=25°C ( K = -3.5x10 <sup>-8</sup> / °C <sup>2</sup> )

The above mentioned value is only for your reference. The value is for the arbitrary samples and does not guarantee the product's characteristics. Please review and check above parameters at customer's end.

**Seiko Instruments USA Inc.**

2990,West Lomita Blvd., Torrance, CA 90505, U.S.A  
 Telephone :+1 310-517-7771 Facsimile :+1 310-517-7792  
 Email :info@siu-la.com

**Seiko Instruments GmbH**

Siemensstrasse 9,D-63263 Neu-Isenburg,Germany  
 Telephone :+49-6102-297-0 Facsimile :+49-6102-297-320  
 Email :info@seiko-instruments.de

**Seiko Instruments Inc.**

1-8,Nakase,Mihama-ku,Chiba-shi,Chiba 261-8507,Japan  
 Facsimile :+81-43-211-8030  
 E-mail :component@sii.co.jp

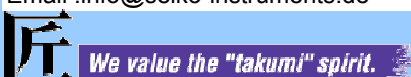

**Evaluation of a Low Frequency Clock Oscillation Circuit**

SSP-T7-FL 6.0pF with uPD78F1014GC-16BT [LQFP(14x14) 0.5mm pitch]

Measurement conditions : 3.0V



Low current consumption mode

Test Data at 25°C

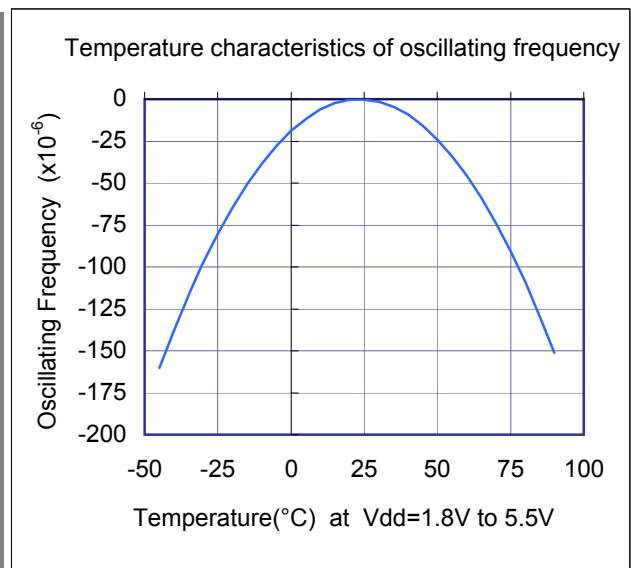
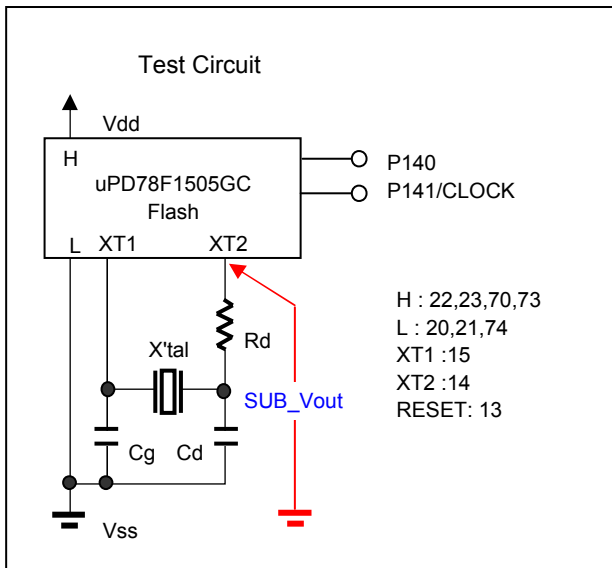
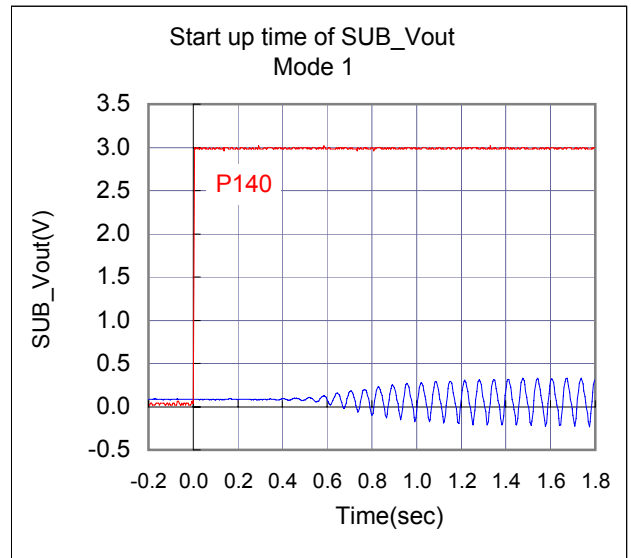
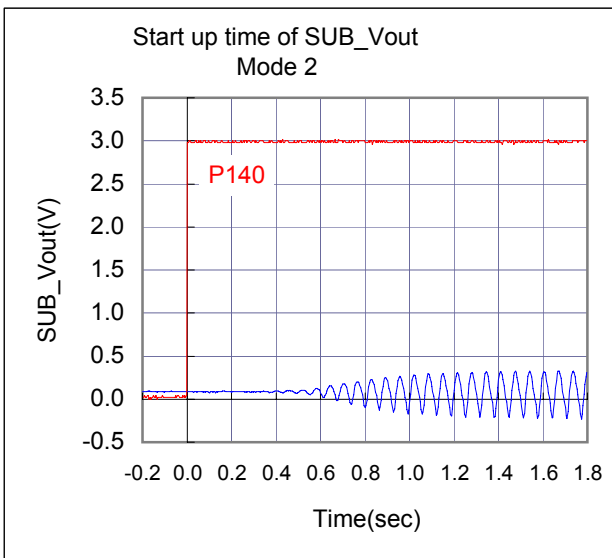
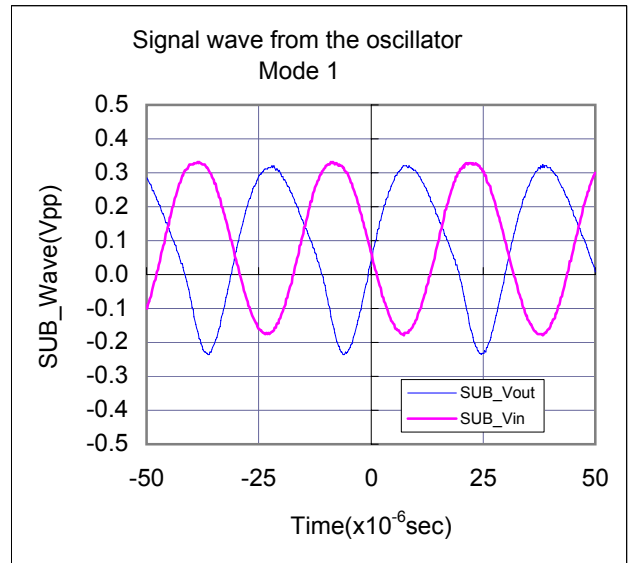
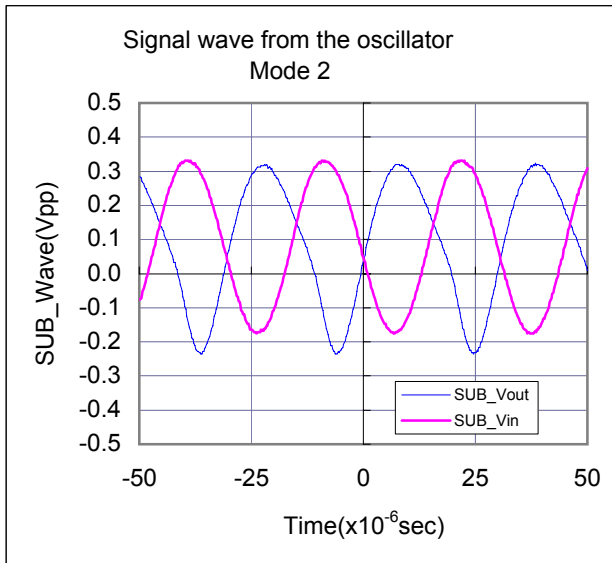

**Evaluation of a Low Frequency Clock Oscillation Circuit**

SSP-T7-FL 6.0pF with uPD78F1014GC-16BT [LQFP(14x14) 0.5mm pitch]

Measurement conditions : 3.0V



Low current consumption mode

Test Data : Temperature characteristics

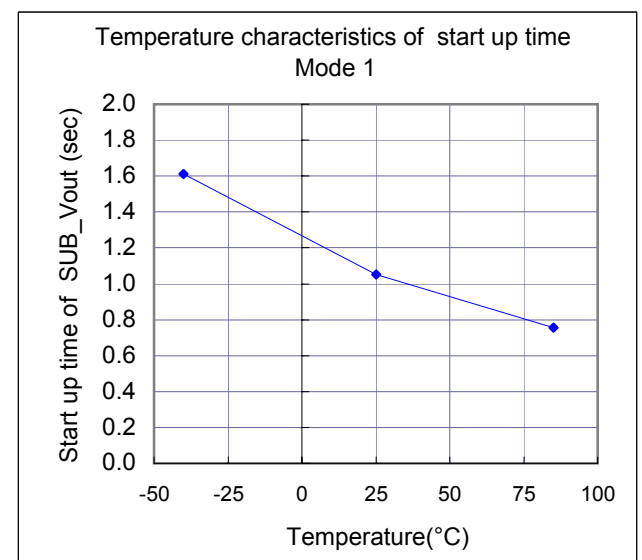
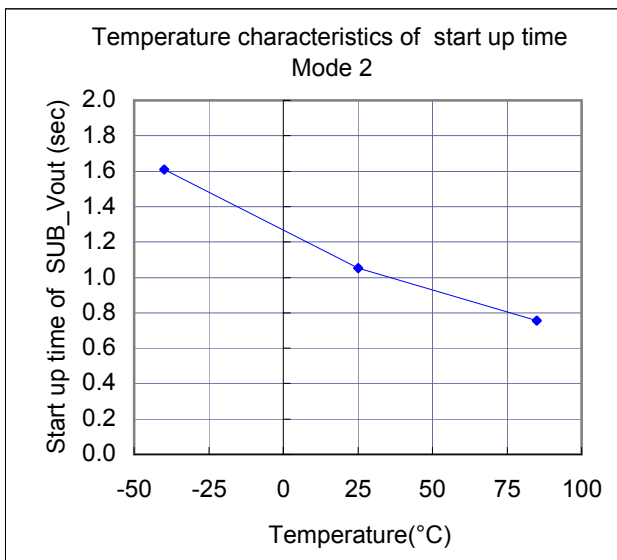
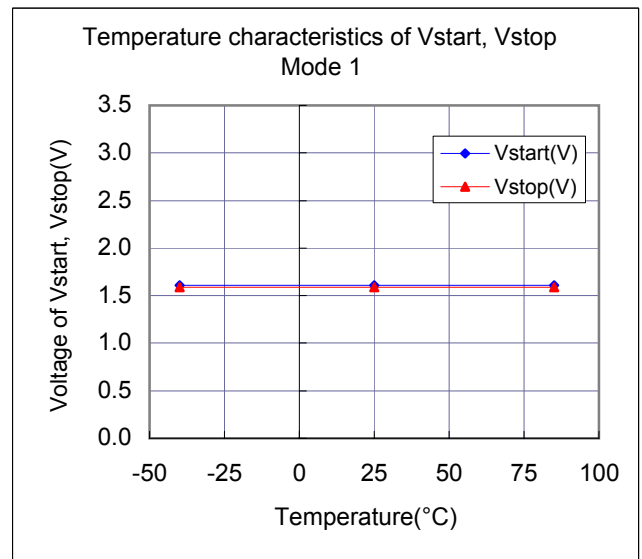
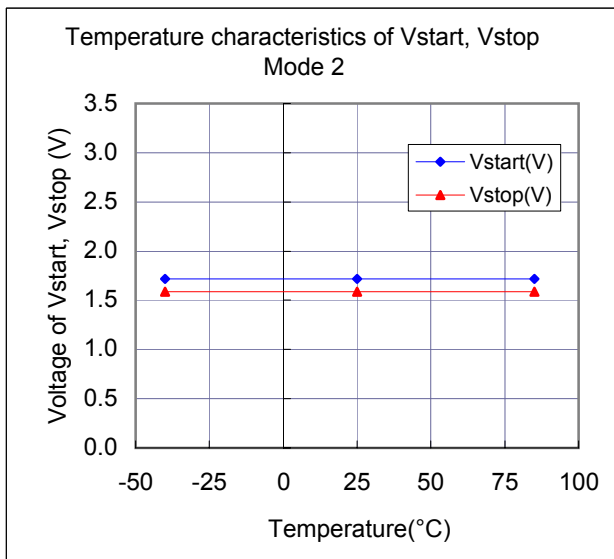
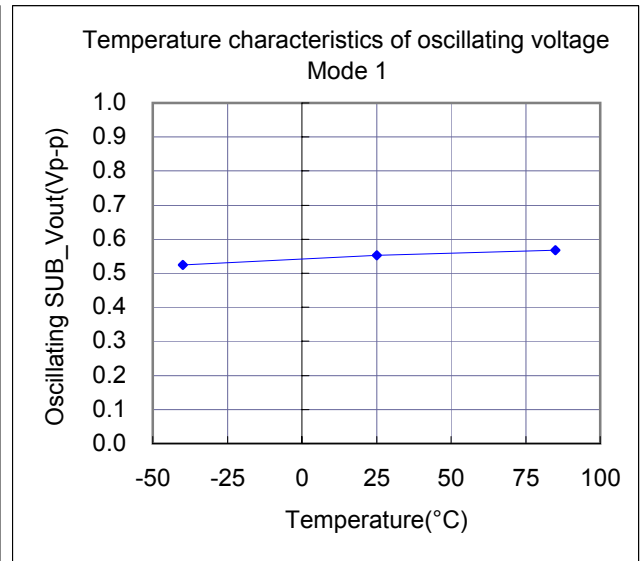
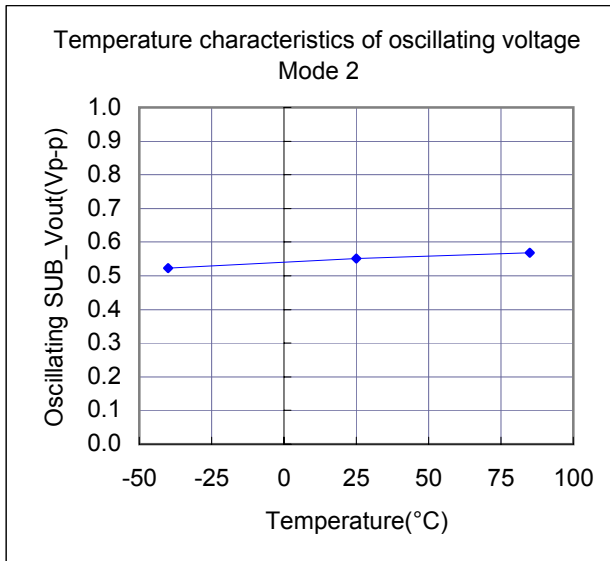

**Evaluation of a Low Frequency Clock Oscillation Circuit**

SSP-T7-FL 6.0pF with uPD78F1014GC-16BT [LQFP(14x14) 0.5mm pitch]

Measurement conditions : 3.0V



Low current consumption mode

**Referential components layout(see Figure 1)**

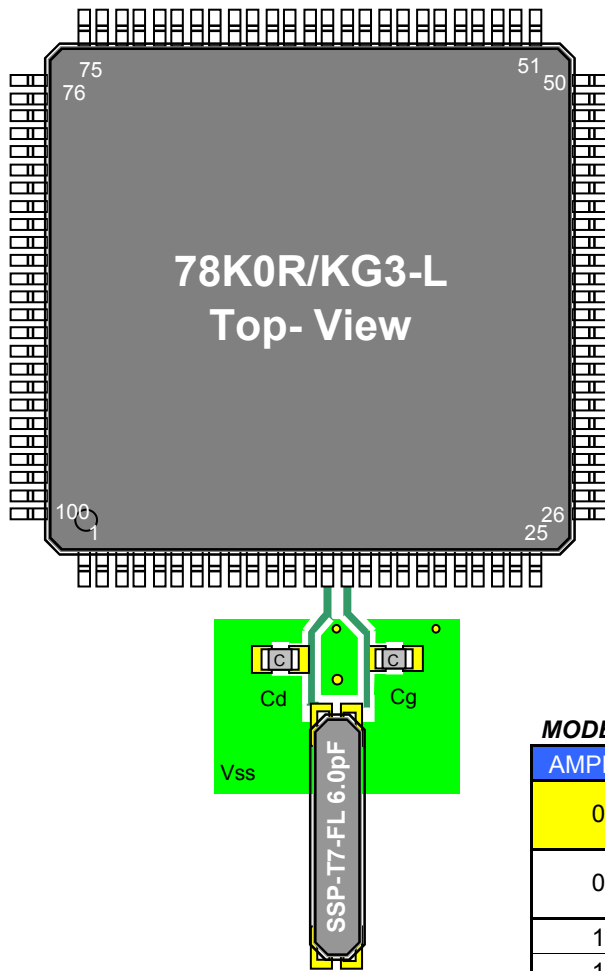

*78K0R/Kx3-L series*

*\*78K0R/KF3-L*

*uPD78F1010*

*uPD78F1011*

*uPD78F1012*

*\*78K0R/KG3-L*

*uPD78F1013*

*uPD78F1014*

**MODEL:SSP-T7-FL 6.0pF with uPD78F1014GC at 25°C**

AMPHS1	AMPHS0	Oscillation mode selection
0	0	Low consumption oscillation mode. (default) ; Id=210nA typ.
0	1	Normal consumption oscillation mode. Id=370nA typ.
1	0	Extremely low consumption oscillation mode. Id=120nA typ.
1	1	

**Figure 1 Referential components layout**

**Notes for Board Design**

When using a crystal resonator, place the resonator and its load capacitors as close as possible to SUB\_in and SUB\_out pins.

Other signal lines should be routed away from the resonator circuit to prevent induction from interfering with correct oscillation (see figure 2).

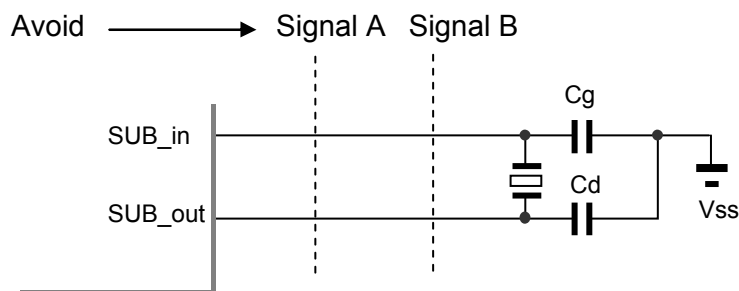

**Figure 2 Example of Incorrect Board Design**

**Remark** When using the subsystem clock, insert a resistor, Rd, in series on the SUB\_out side.

**Evaluation of a Low Frequency Clock Oscillation Circuit**

SSP-T7-FL 6.0pF with uPD78F1014GC-16BT [LQFP(14x14) 0.5mm pitch]

Measurement conditions : 3.0V



Low current consumption mode

**[Evaluation Sample at 25°C]**

SAMPLE	No.	CL( pF )	Fo( Hz )	fr( Hz )	R1( kΩ )	Co( pF )	C1( fF )	Q( k )
SSP-T7-FL	1	6.0	32768.05	32763.13	39.2	0.89	2.070	59.9
	2	6.0	32767.91	32762.99	41.9	0.89	2.070	56.0
	3	6.0	32768.01	32763.08	35.4	0.90	2.076	66.1

**[IC Test Data : IC sample Rd=0Ω,Cg=9pF,Cd=8pF at 25°C]**

MODE	IC sample	Fosc( Hz )	df / f( x10 <sup>-6</sup> )	DL(μW)	M(times)	XT2(Vpp)	Id(nA)	Vstart( V )	Ts(sec)
Mode 1	Sample 1	32768.06	1.9	0.02	7	0.58	219	1.58	1.19
	Sample 2	32768.05	1.6	0.02	7	0.54	203	1.58	1.17
	Sample 3	32768.05	1.6	0.02	8	0.55	207	1.61	1.05
	Sample 4	32768.06	1.7	0.01	9	0.59	222	1.59	0.93
	Sample 5	32768.04	1.3	0.01	7	0.54	205	1.59	0.94

**[IC Test Data : IC sample Rd=0Ω,Cg=9pF,Cd=8pF at 25°C]**

MODE	IC sample	Fosc( Hz )	df / f( x10 <sup>-6</sup> )	DL(μW)	M(times)	XT2(Vpp)	Id(nA)	Vstart( V )	Ts(sec)
Mode 2	Sample 1	32768.06	1.7	0.02	7	0.58	219	1.67	1.19
	Sample 2	32768.04	1.3	0.02	7	0.54	203	1.68	1.17
	Sample 3	32768.05	1.4	0.02	8	0.55	208	1.72	1.05
	Sample 4	32768.05	1.6	0.01	9	0.59	222	1.69	0.93
	Sample 5	32768.04	1.2	0.01	7	0.54	205	1.70	0.94

**Remark ( see figure 3 )**

$$F_o = f_r \times \left\{ \frac{C_1}{2 \times (C_o + C_L)} + 1 \right\} \text{ ( Hz )}$$

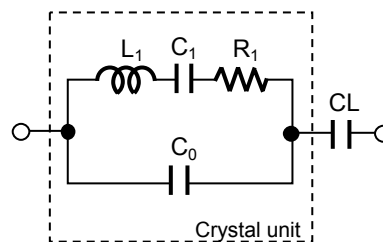

Fo : Load resonance frequency  
fr : Resonance frequency  
R1 : Motional resistance  
C1 : Motional capacitance  
Co : Shunt capacitance  
CL : Load Capacitance

**Figure 3 Equivalent circuit of crystal unit, and CL****Remark ( see figure 4 )**

Approximate formula of the load capacitance of the circuit CL,

$$C_L = C_g \times C_d / (C_g + C_d) + C_s \text{ (pF)}$$

$$C_s = C_{gs} \times C_{ds} / (C_{gs} + C_{ds}) + C_{os} \text{ (pF)}$$

where Cs(=1.5 to 2.5pF) stands for stray capacitance of the circuit.

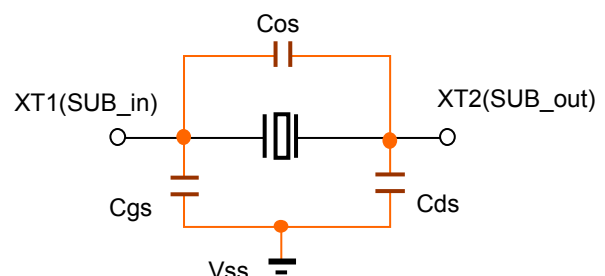

Cos : X1\_X2 Stray capacitance  
Cgs : X1\_Vss Stray capacitance  
Cds : X2\_Vss Stray capacitance

**Figure 4 Stray capacitance Cos,Cgs,Cds of the circuit**

Resonator circuit constants differ depending on the resonator element, stray capacitance in its interconnecting circuit, and other factors. Suitable constants should be determined in consultation with the resonator element manufacturer.



**Evaluation of a Low Frequency Clock Oscillation Circuit**

SSP-T7-FL 6.0pF with uPD78F1014GC-16BT [LQFP(14x14) 0.5mm pitch]

Measurement conditions : Vcc=(1.6V) to (6.0V) at 25°C



Low current consumption mode

Referential Data(1) : Voltage characteristics

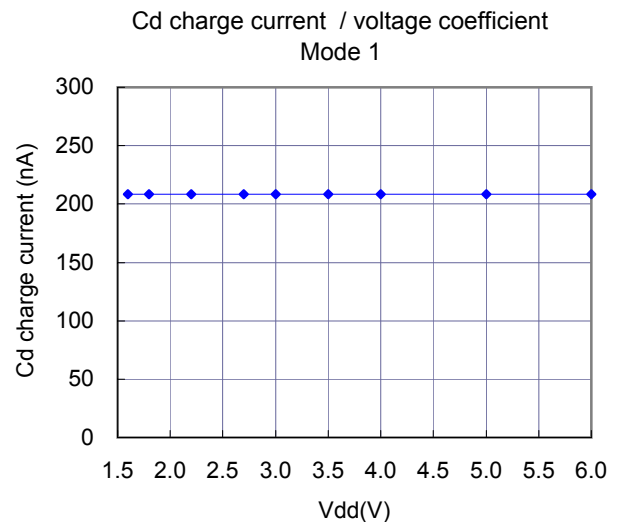
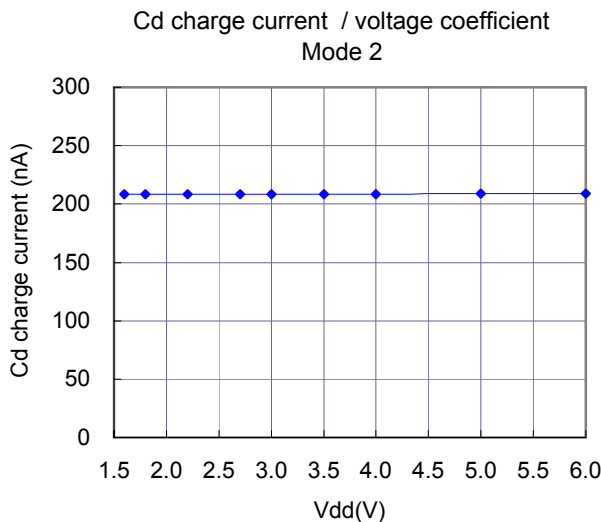
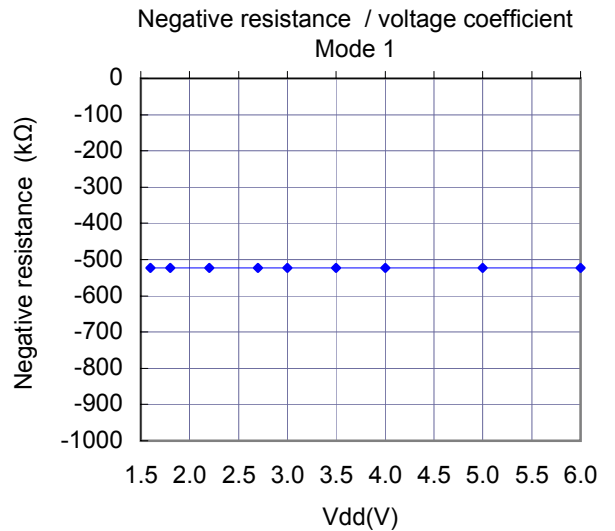
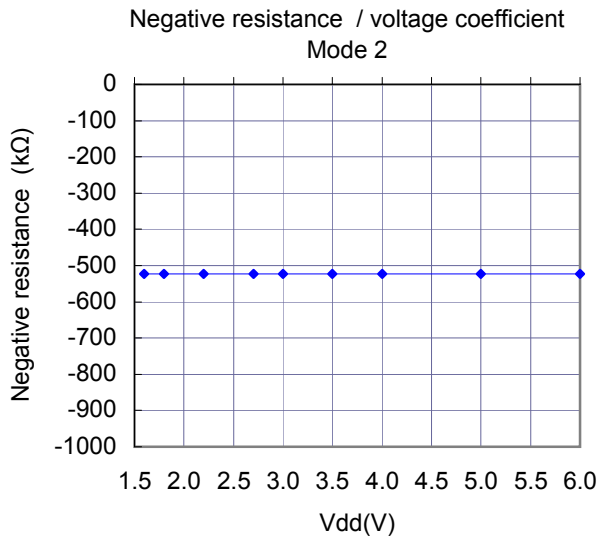
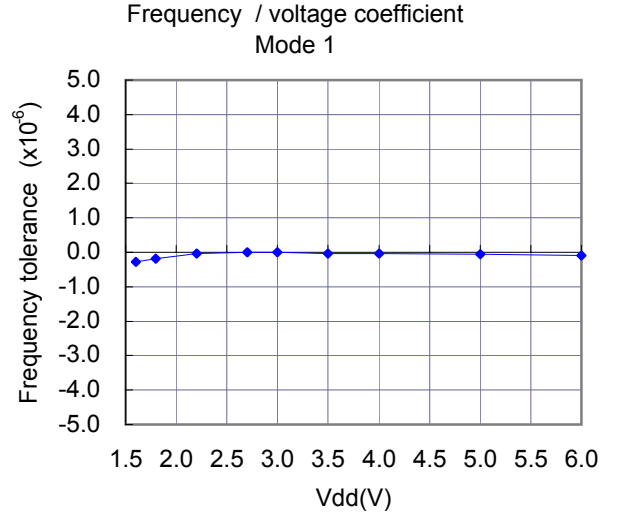
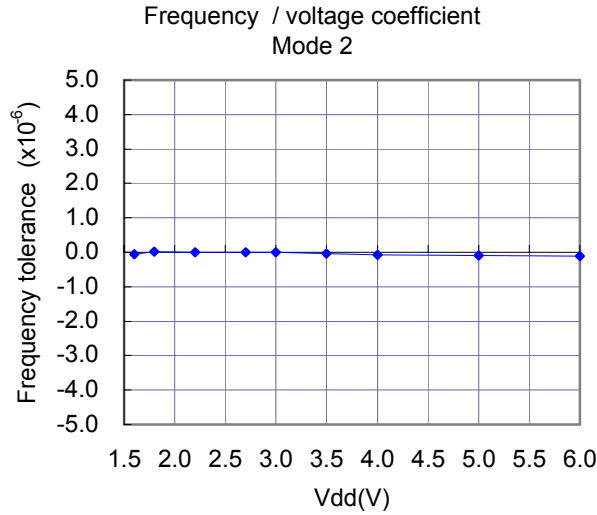

**Evaluation of a Low Frequency Clock Oscillation Circuit**

SSP-T7-FL 6.0pF with uPD78F1014GC-16BT [LQFP(14x14) 0.5mm pitch]

Measurement conditions : Vcc=(1.6V) to (6.0V) at 25°C



Low current consumption mode

Referential Data(2) : Voltage characteristics

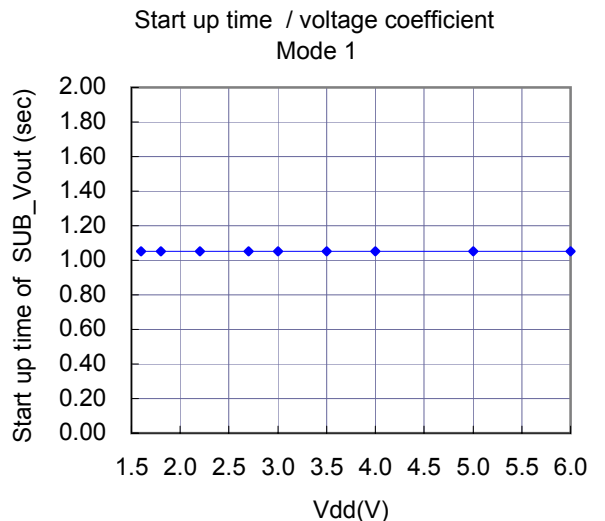
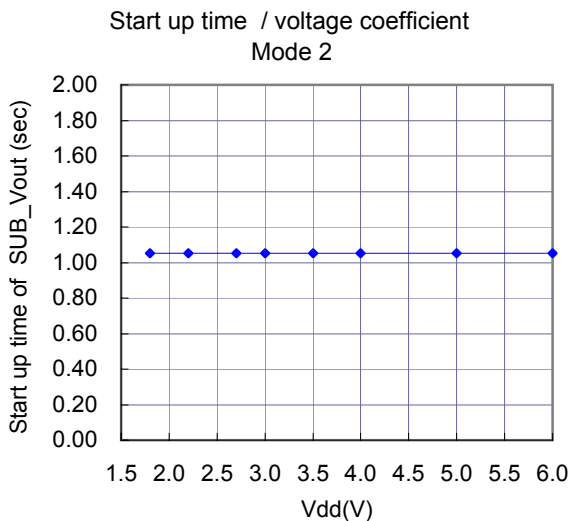
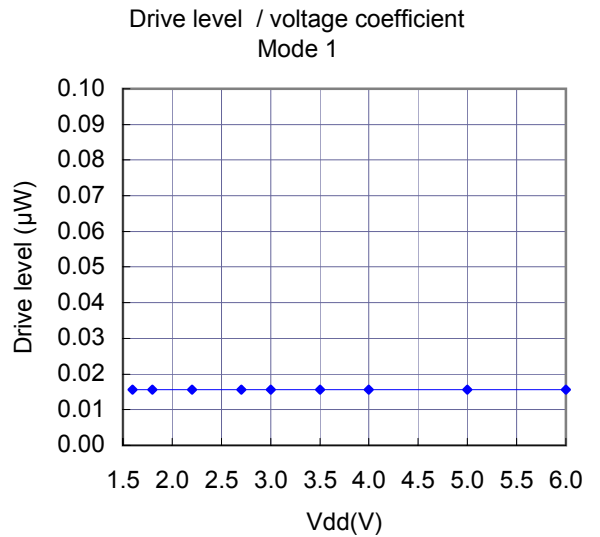
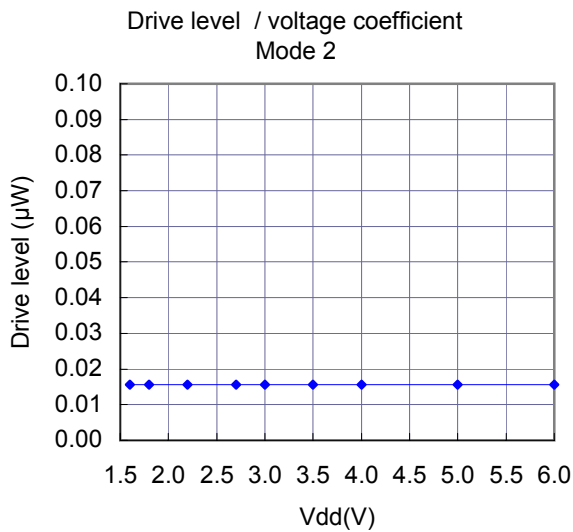
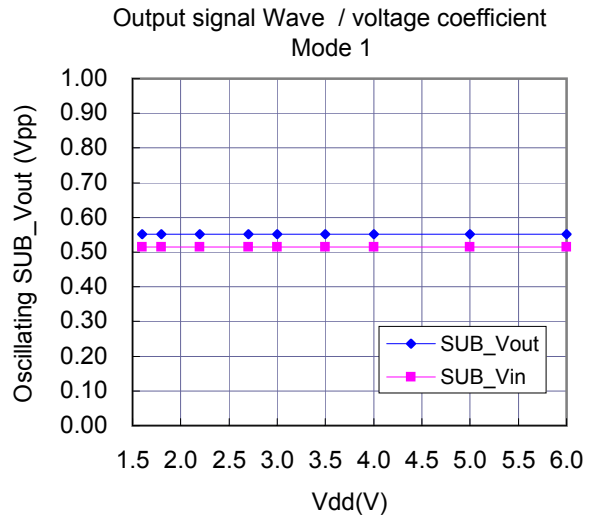
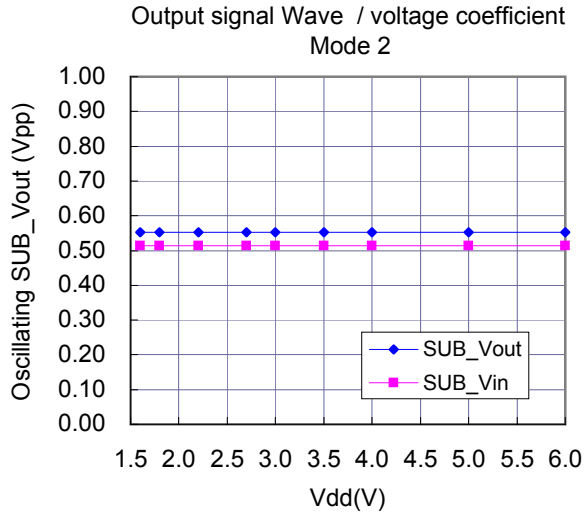

**Evaluation of a Low Frequency Clock Oscillation Circuit**

SSP-T7-FL 6.0pF with uPD78F1014GC-16BT [LQFP(14x14) 0.5mm pitch]

Measurement conditions : Vdd=3.0V at 25°C



Low current consumption mode

Referential Data(3) : Mode 3 characteristics

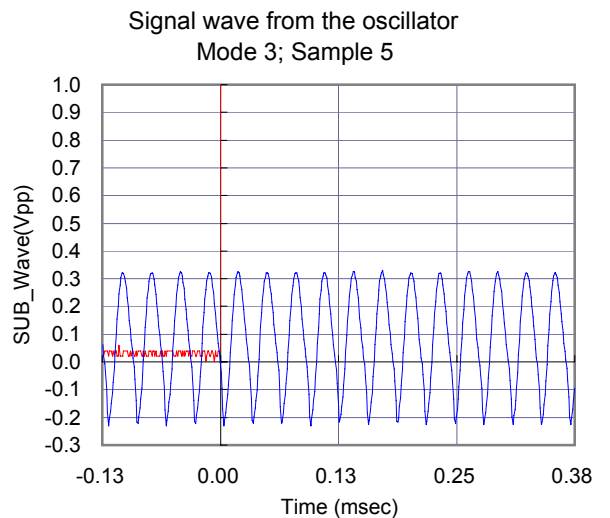
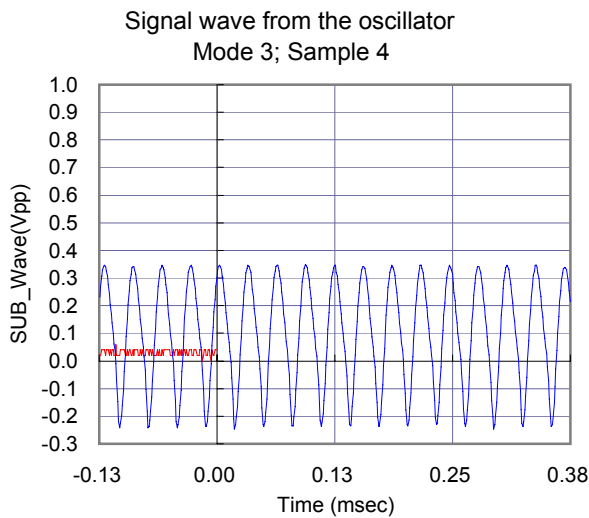
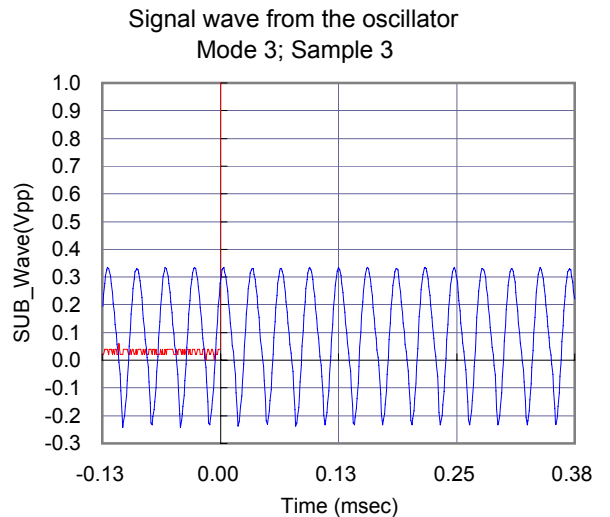
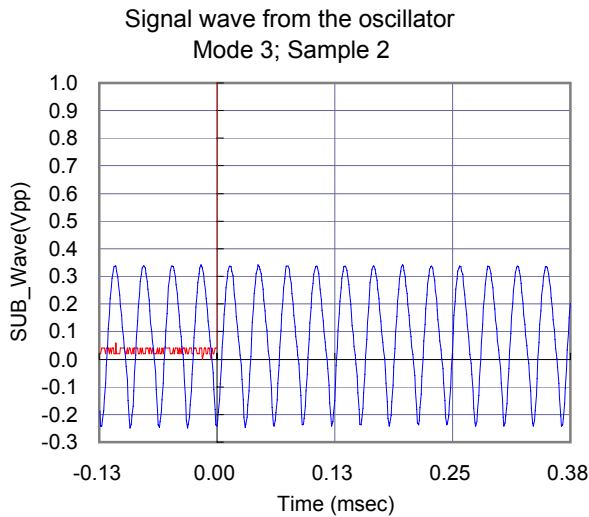
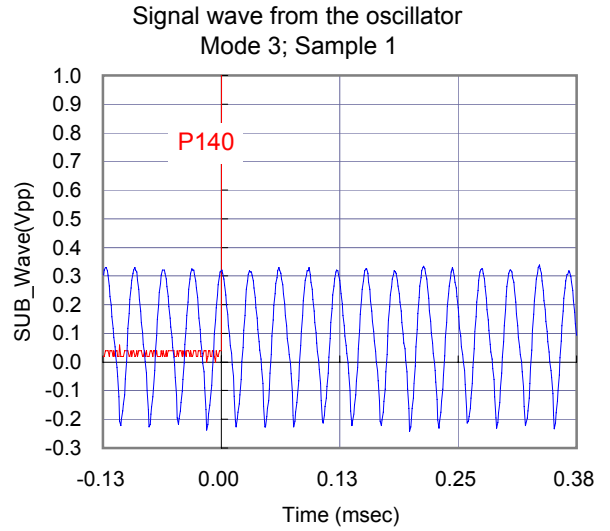
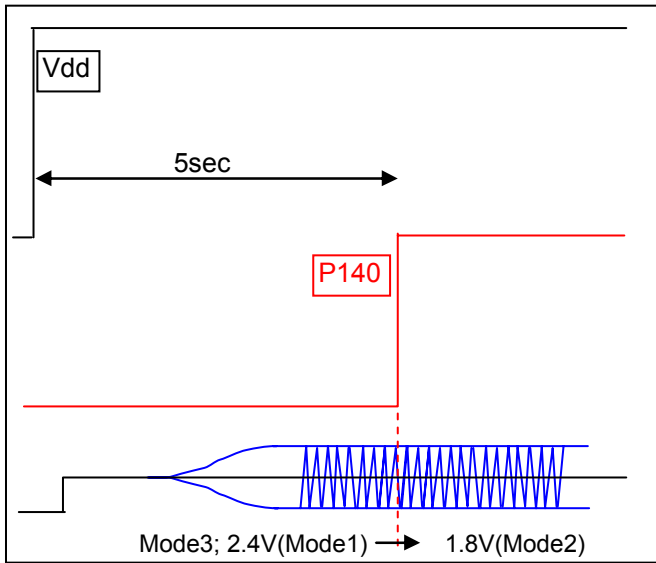

**Evaluation of a Low Frequency Clock Oscillation Circuit**

SSP-T7-FL 6.0pF with uPD78F1014GC-16BT [LQFP(14x14) 0.5mm pitch]

Measurement conditions : V<sub>dd</sub>=3.0V at 25°C



Low current consumption mode

Referential Data(4) : Load capacitance characteristics(Low,Normal,Extremely low)

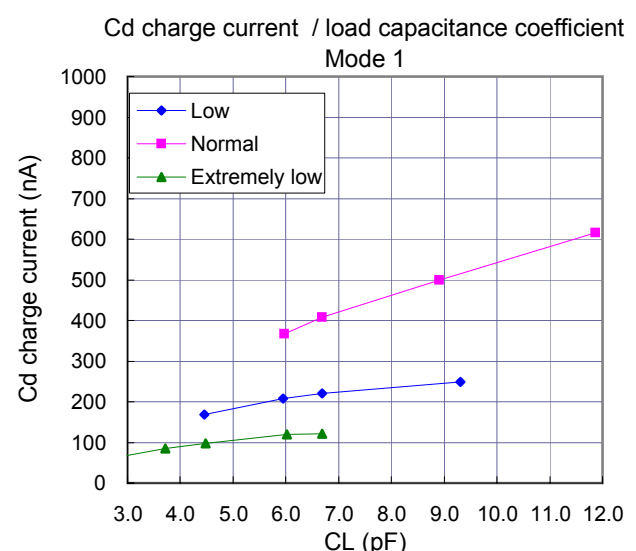
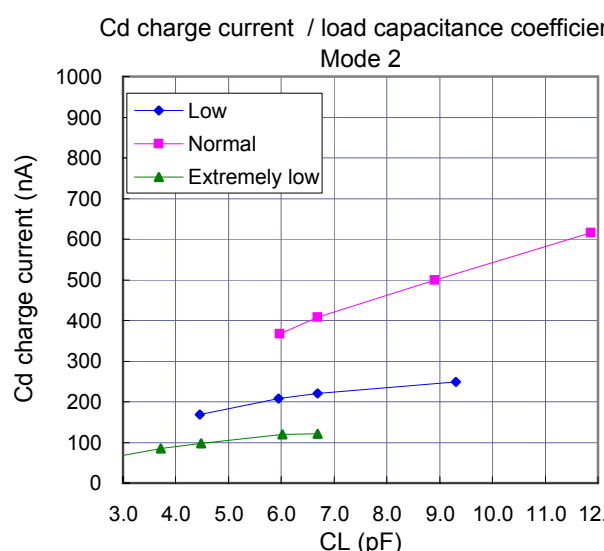
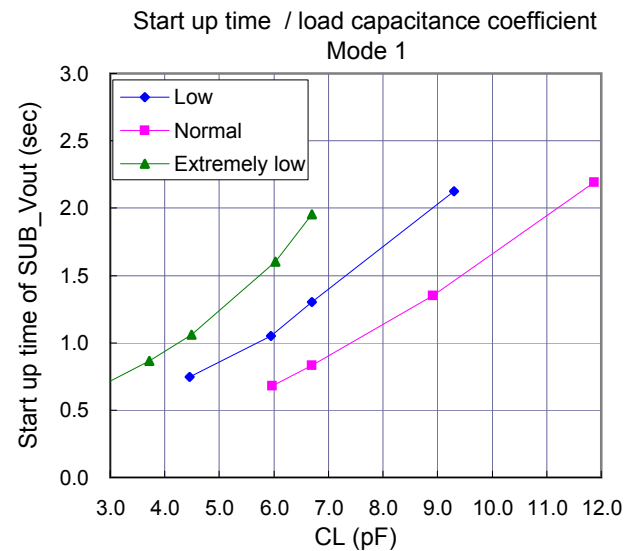
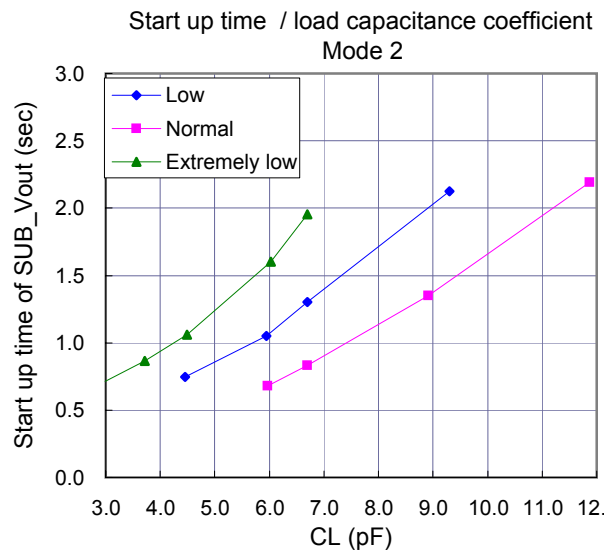
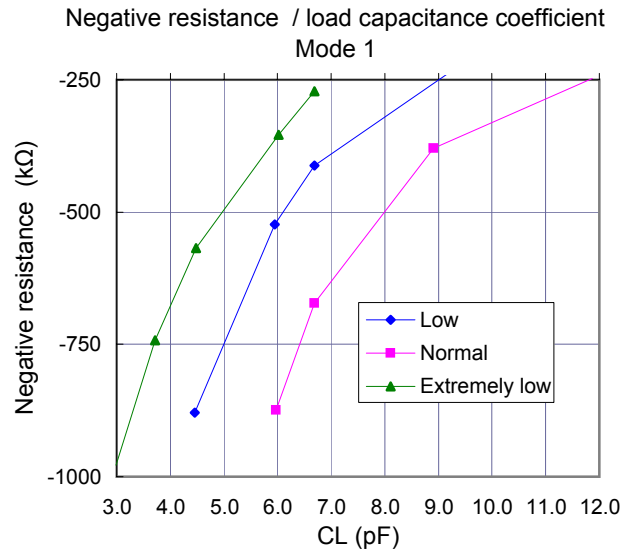
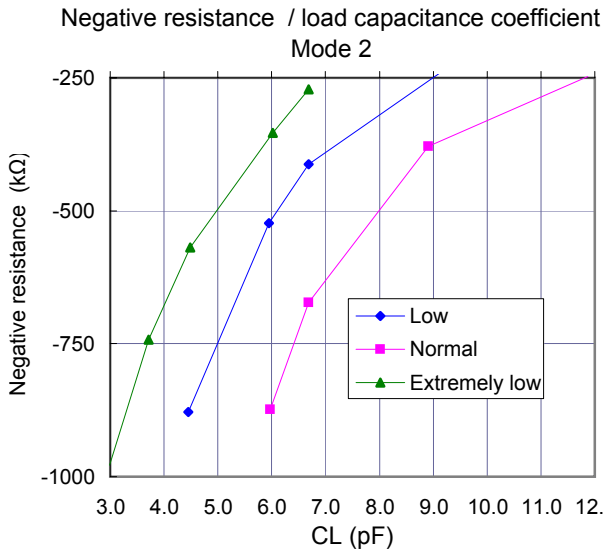

**Evaluation of a Low Frequency Clock Oscillation Circuit**

SSP-T7-FL 6.0pF with uPD78F1014GC-16BT [LQFP(14x14) 0.5mm pitch]

Measurement conditions : V<sub>dd</sub>=3.0V at 25°C

Low current consumption mode

Referential Data(5) : IC sample characteristics(Low,Normal,Extremely low)



Table 1 Oscillation mode selection of XT1 oscillation circuit and load capacitance for a resonator

AMPHS1	AMPHS0	Oscillation mode selection	Recommended load capacitance (Cd charge current)
0	0	Low consumption oscillation mode.(default)	6.0pF (210nA typ)
0	1	Normal consumption oscillation mode.	6.0pF (370nA typ),7.0pF (410nA typ),9.0pF(500nA typ)
1	0	Extremely low consumption oscillation mode.	6.0pF (120nA typ),3.7pF (80nA typ)
1	1	(DC bias current; 200nA max. at 25°C)	3.0pF(65nA typ)

\*78K0R/Kx3-L series;  $\mu$ PD78F1010 to  $\mu$ PD78F1014 & SSP-T7 seriesLow current consumption mode; IC sample Rd=0 $\Omega$ ,Cg=9pF,Cd=8pF,CL=6.0pF

MODE	IC sample	Fosc( Hz )	df / f( x10-6 )	DL( $\mu$ W)	M(times)	XT2(Vpp)	I <sub>d</sub> (nA)	Vstart( V )	T <sub>s</sub> (sec)
Mode 1 (2.4V)	Sample 1	32768.06	1.9	0.018	7	0.58	219	1.58	1.19
	Sample 2	32768.05	1.6	0.016	7	0.54	203	1.58	1.17
	Sample 3	32768.05	1.6	0.016	8	0.55	207	1.61	1.05
	Sample 4	32768.06	1.7	0.012	9	0.59	222	1.59	0.93
	Sample 5	32768.04	1.3	0.012	7	0.54	205	1.59	0.94
Mode 2 (1.8V)	Sample 1	32768.06	1.7	0.018	7	0.58	219	1.67	1.19
	Sample 2	32768.04	1.3	0.016	7	0.54	203	1.68	1.17
	Sample 3	32768.05	1.4	0.016	8	0.55	208	1.72	1.05
	Sample 4	32768.05	1.6	0.012	9	0.59	222	1.69	0.93
	Sample 5	32768.04	1.2	0.012	7	0.54	205	1.70	0.94

Normal current consumption mode; IC sample Rd=0 $\Omega$ ,Cg=9pF,Cd=8pF,CL=6.0pF

MODE	IC sample	Fosc( Hz )	df / f( x10-6 )	DL( $\mu$ W)	M(times)	XT2(Vpp)	I <sub>d</sub> (nA)	Vstart( V )	T <sub>s</sub> (sec)
Mode 1 (2.4V)	Sample 1	32768.05	1.5	0.022	11	1.00	409	1.58	0.77
	Sample 2	32768.05	1.5	0.022	12	0.96	392	1.58	0.77
	Sample 3	32768.03	1.0	0.018	13	0.92	379	1.61	0.68
	Sample 4	32768.02	0.7	0.015	15	0.84	348	1.59	0.71
	Sample 5	32768.01	0.4	0.014	12	0.83	343	1.59	0.70
Mode 2 (1.8V)	Sample 1	32768.04	1.3	0.022	11	1.00	410	1.67	0.77
	Sample 2	32768.04	1.3	0.022	12	0.96	393	1.68	0.77
	Sample 3	32768.03	0.8	0.018	13	0.92	379	1.72	0.68
	Sample 4	32768.02	0.6	0.015	15	0.84	349	1.69	0.71
	Sample 5	32768.01	0.2	0.014	12	0.83	343	1.70	0.70

Extremely low current consumption mode; IC sample Rd=0 $\Omega$ ,Cg=9pF,Cd=8pF,CL=6.0pF

MODE	IC sample	Fosc( Hz )	df / f( x10-6 )	DL( $\mu$ W)	M(times)	XT2(Vpp)	I <sub>d</sub> (nA)	Vstart( V )	T <sub>s</sub> (sec)
Mode 1 (2.4V)	Sample 1	32768.01	0.2	0.008	5	0.35	122	1.58	1.79
	Sample 2	32767.98	-0.6	0.007	5	0.32	112	1.58	1.69
	Sample 3	32768.02	0.5	0.007	5	0.34	119	1.61	1.60
	Sample 4	32768.02	0.5	0.008	6	0.37	127	1.59	1.45
	Sample 5	32767.99	-0.2	0.007	5	0.33	114	1.59	1.44
Mode 2 (1.8V)	Sample 1	32768.00	0.0	0.008	5	0.35	122	1.67	1.79
	Sample 2	32767.97	-0.8	0.007	5	0.32	112	1.68	1.69
	Sample 3	32768.01	0.3	0.007	5	0.34	119	1.72	1.60
	Sample 4	32768.01	0.3	0.008	6	0.37	127	1.69	1.45
	Sample 5	32767.99	-0.4	0.007	5	0.33	114	1.70	1.44

**Evaluation of a Low Frequency Clock Oscillation Circuit**

SSP-T7-FL 6.0pF with uPD78F1014GC-16BT [LQFP(14x14) 0.5mm pitch]

Measurement conditions : V<sub>dd</sub>=3.0V at 25°C



Low current consumption mode

Referential Data(5) : Selection of XT1 oscillation mode and recommended load capacitance

**For 78K0R/Kx3-L series**

XT1 oscillation circuit has the function (via software) to select the XT1 oscillation mode.

The XT1 oscillation mode can be switched over just one time among normal oscillation (Normal), low consumption oscillation (Low), and "extremely low consumption oscillation" mode (E-Low).

Correlations between the oscillation mode selection of XT1 oscillation circuit and the recommended load capacitance for a resonator are shown in Table 1 for safety use.

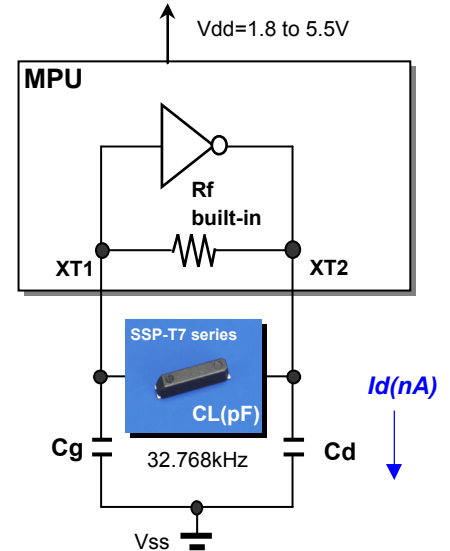

SSP-T7 series

SSP-T7-FL CL=3.0pF, 3.7pF, 4.4pF, 6.0pF and SSP-T7-F CL=7.0pF, 9.0pF

**Table 1 Oscillation mode selection of XT1 oscillation circuit and load capacitance for a resonator**

XT1 oscillation mode selection	Recommended circuit constant and load capacitance for a resonator				
	C <sub>g</sub> =3pF, C <sub>d</sub> =2pF	C <sub>g</sub> =4pF, C <sub>d</sub> =3pF	C <sub>g</sub> =9pF, C <sub>d</sub> =8pF	C <sub>g</sub> =10pF, C <sub>d</sub> =10pF	C <sub>g</sub> =15pF, C <sub>d</sub> =15pF
<b>E-Low</b> Extremely low consumption oscillator	<b>SSP-T7-FL 3.0pF</b> <i>Id=65nA typ</i> <i>RL=-990kΩ typ</i> <i>Ts=0.75sec typ</i>	<b>SSP-T7-FL 3.7pF</b> <i>Id=80nA typ</i> <i>RL=-730kΩ typ</i> <i>Ts=0.85sec typ</i>	<b>SSP-T7-FL 6.0pF</b> <i>Id=120nA typ</i> <i>RL=-340kΩ typ</i> <i>Ts=1.60sec typ</i>	<i>Not recommended.</i>	<i>Not recommended.</i>
<b>Low</b> Low consumption oscillator	<i>Not recommended.</i>	<i>Not recommended.</i>	<b>SSP-T7-FL 6.0pF</b> <i>Id=210nA typ</i> <i>RL=-500kΩ typ</i> <i>Ts=1.05sec typ</i>	<b>SSP-T7-F 7.0pF</b> <i>Id=230nA typ</i> <i>RL=-410kΩ typ</i> <i>Ts=1.30sec typ</i>	<i>Not recommended.</i>
<b>Normal</b> Normal oscillation	<i>Not recommended.</i>	<i>Not recommended.</i>	<b>SSP-T7-FL 6.0pF</b> <i>Id=370nA typ</i> <i>RL=-835kΩ typ</i> <i>Ts=0.70sec typ</i>	<b>SSP-T7-F 7.0pF</b> <i>Id=410nA typ</i> <i>RL=-660kΩ typ</i> <i>Ts=0.85sec typ</i>	<b>SSP-T7-F 9.0pF</b> <i>Id=500nA typ</i> <i>RL=-380kΩ typ</i> <i>Ts=1.40sec typ</i>

**NEC MPU 78K0R/Kx3-L series**

- 78K0R/KF3-L; uPD78F1010
- uPD78F1011
- uPD78F1012
- 78K0R/KG3-L; uPD78F1013
- uPD78F1014

