

Evaluation of a Low Frequency Clock Oscillation Circuit

SSP-T7 7.0pF with uPD78F1505GC-16BT [LQFP(14x14) 0.5mm pitch]

Measurement conditions : 3.0V



Model :SSP-T7
 Frequency :Fo=32.768kHz
 Frequency tolerance :dF/Fo= +/-20x10⁶
 Load capacitance :CL=7.0pF
 Equivalent series resistance :R1=65kΩ max
 Max. drive level :DL=1μW max
 Level of drive :DL=0.1μW typ

FEATURES

- 1.Ultra thin type with 1.4mm Max.
- 2.SMD type suitable for automatic & high density surface mounting.
- 3.Plastic mold package containing highly reliable tubular type quartz crystal.
- 4.Excellent shock and heat resistance.
- 5.Cellular phones,PDA,Radio communication equipment, Portable applications etc.

RECOMMENDED SOLDERING PATTERN

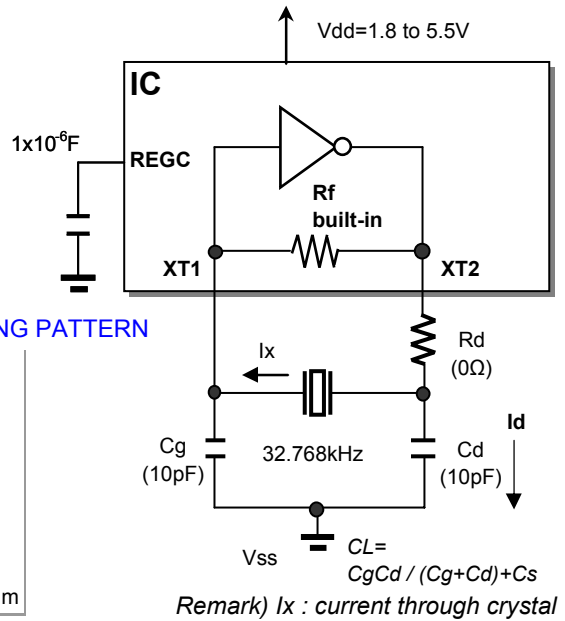
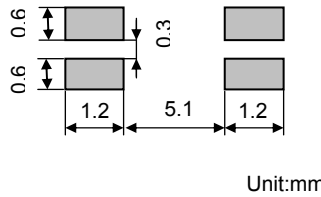

	REGVDD	Oscillation mode
Mode 1	2.4V	Normal (*1)
Mode 2	1.8V	

*1 ; Normal current consumption mode

MODEL:SSP-T7 7.0pF with uPD78F1505GC at 25°C

Key specifications	Mode 2	Mode 1	Remarks
Current control resistance : Rd (kΩ)	0	0	Control drive level & secure phase margin
Capacitance at gate : Cg (pF)	10	10	Optimal capacitance in response to CL
Capacitance at drain : Cd (pF)	10	10	(CL = Cd // Cg + stray capacitance)

Circuit characteristics (at 25°C)	Mode 2	Mode 1	Remarks
Matching Accuracy : df / f (x10 ⁻⁶)	2.4	2.5	Frequency offset volume at specified Vdd
Voltage Fluctuation : +/-df / V (x10 ⁻⁶)	0.0	0.0	Vdd +/-10% (Standard operating voltage range)
Drive Level : DL (μW)	0.02	0.02	DL=Ix ² Re < 1x10 ⁻⁶ W, Re=R1(1 + Co / CL) ²
Negative resistance : - RL (kΩ)	718	718	5 times larger than R _{1MAX}
Oscillation allowance : M (times)	11	11	Judgmental standard of oscillation stability
Current consumption : Id (nA)	427	426	Cd charge current, Id = ωCd*Vd < 500nA
Voltage of oscillation start : Vstrat (V)	1.60	1.59	
Voltage of oscillation stop : Vstop (V)	1.57	1.57	
Oscillation start up time : Ts (sec)	0.74	0.74	Time to reach 90% of output level, Ts < 1.0sec

Temperature characteristics of circuit		Mode 2	Mode 1	Remarks
at -40°C	Variation : df / T (x10 ⁻⁶)	-132	-132	Typ.Tp=25°C (K = -3.5x10 ⁻⁸ / °C ²)
at +85°C	Variation : df / T (x10 ⁻⁶)	-138	-138	Typ.Tp=25°C (K = -3.5x10 ⁻⁸ / °C ²)

The above mentioned value is only for your reference. The value is for the arbitrary samples and does not guarantee the product's characteristics. Please review and check above parameters at customer's end.

Seiko Instruments USA Inc.

2990,West Lomita Blvd., Torrance, CA 90505, U.S.A
 Telephone :+1 310-517-7771 Facsimile :+1 310-517-7792
 Email :info@siu-la.com

Seiko Instruments GmbH

Siemensstrasse 9,D-63263 Neu-Isenburg,Germany
 Telephone :+49-6102-297-0 Facsimile :+49-6102-297-320
 Email :info@seiko-instruments.de

Seiko Instruments Inc.

1-8,Nakase,Mihama-ku,Chiba-shi,Chiba 261-8507,Japan
 Facsimile :+81-43-211-8030
 E-mail :component@sii.co.jp

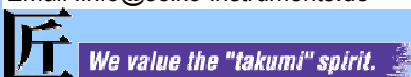

Evaluation of a Low Frequency Clock Oscillation Circuit

SSP-T7 7.0pF with uPD78F1505GC-16BT [LQFP(14x14) 0.5mm pitch]

Measurement conditions : 3.0V



Normal current consumption mode

Test Data at 25°C

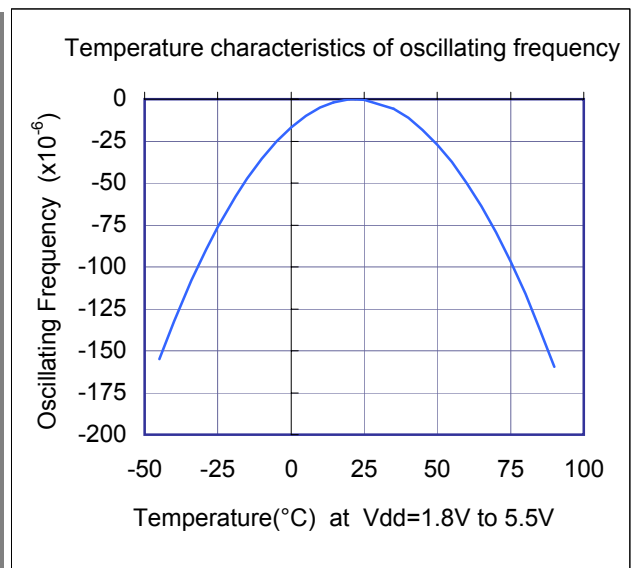
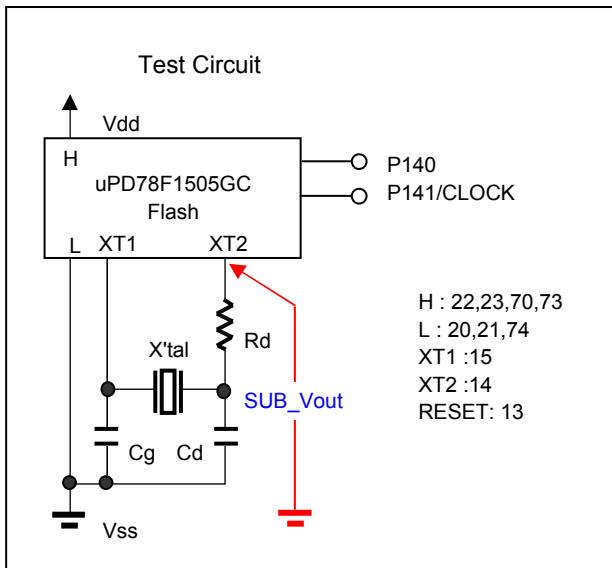
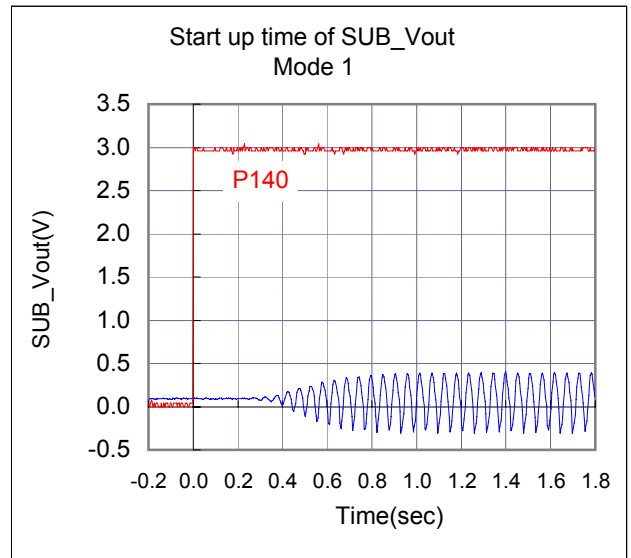
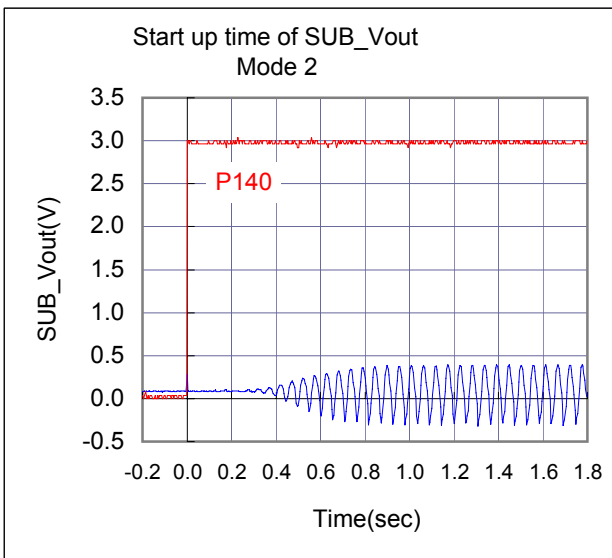
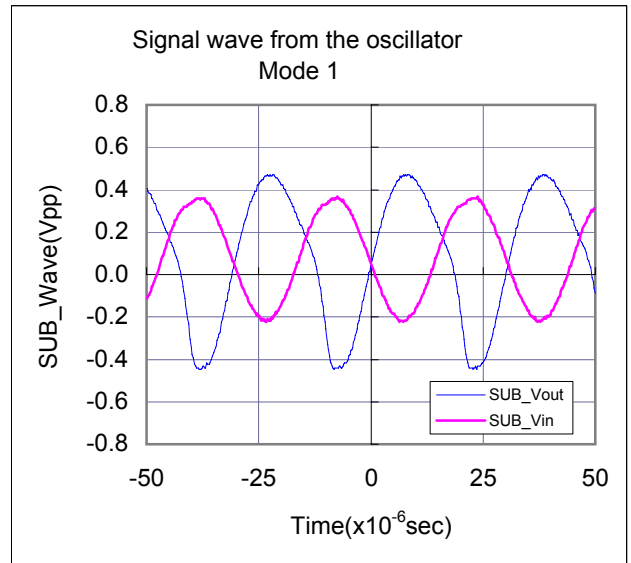
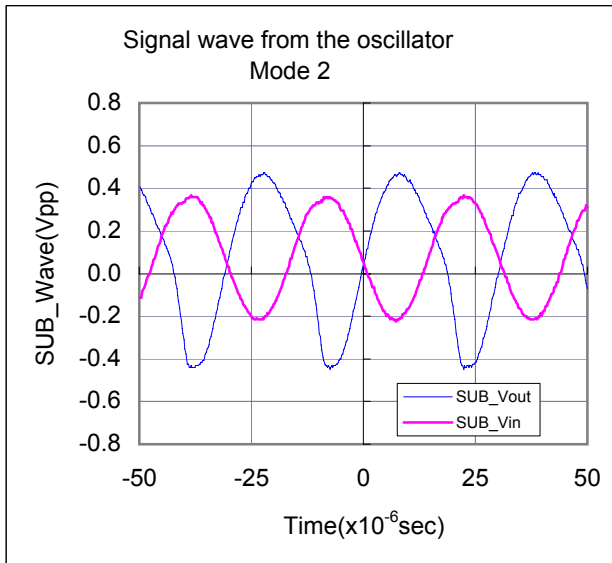

Evaluation of a Low Frequency Clock Oscillation Circuit

SSP-T7 7.0pF with uPD78F1505GC-16BT [LQFP(14x14) 0.5mm pitch]

Measurement conditions : 3.0V



Normal current consumption mode

Test Data : Temperature characteristics

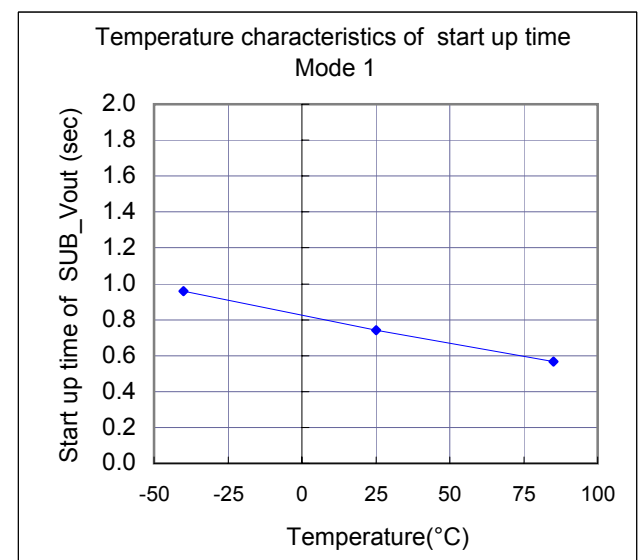
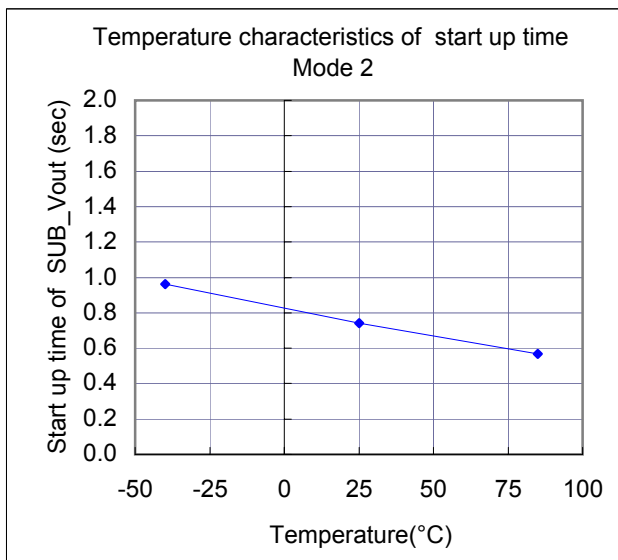
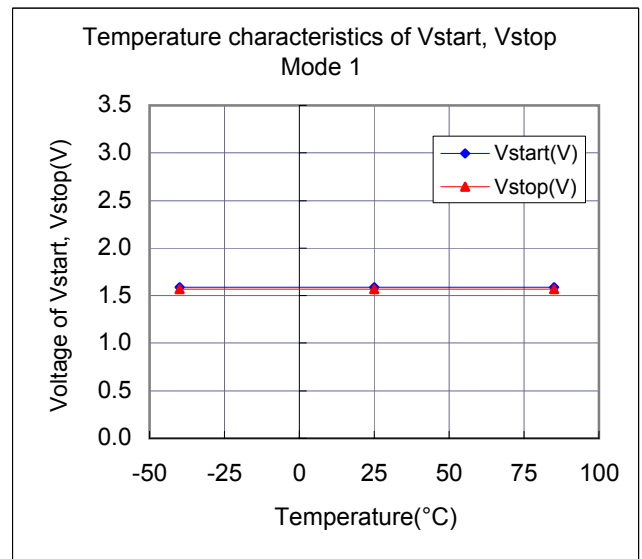
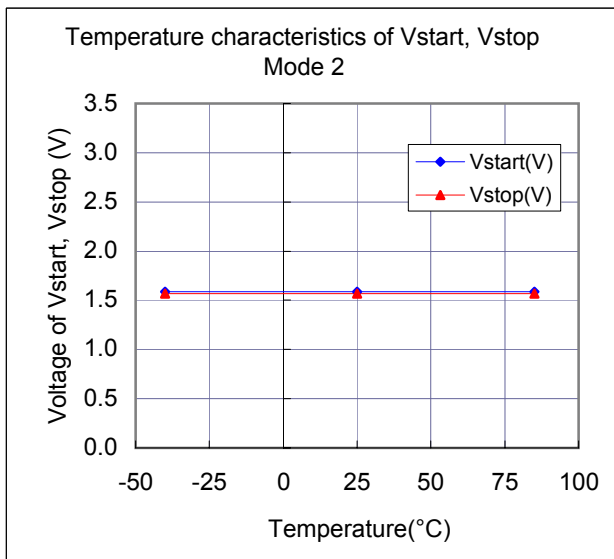
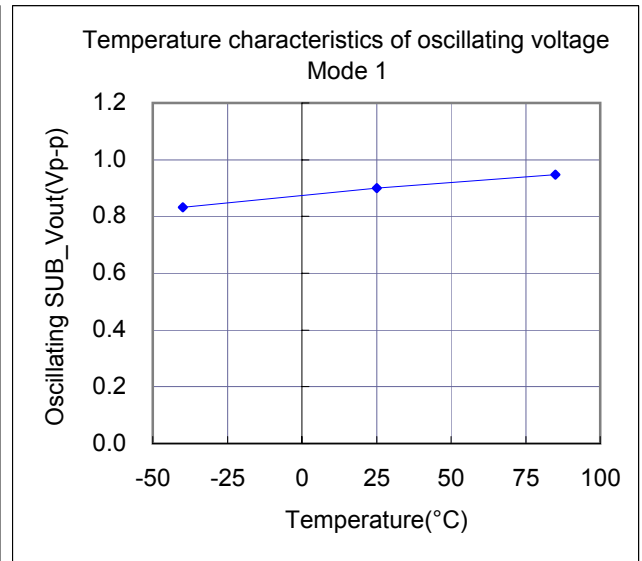
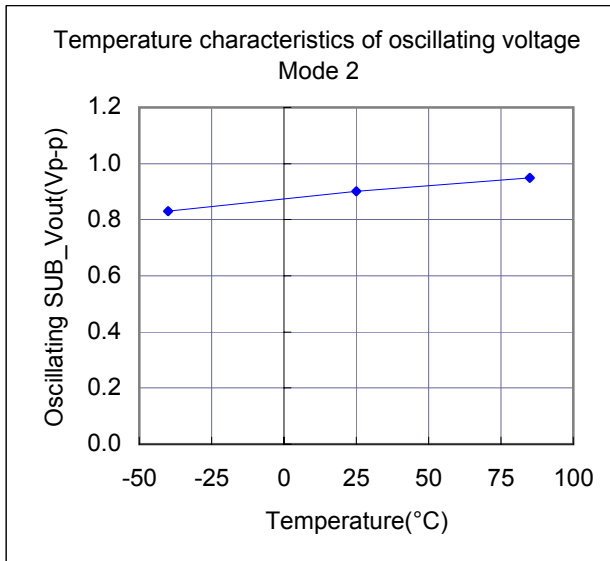

Evaluation of a Low Frequency Clock Oscillation Circuit

SSP-T7 7.0pF with uPD78F1505GC-16BT [LQFP(14x14) 0.5mm pitch]

Measurement conditions : 3.0V



Normal current consumption mode

Referential components layout(see Figure 1)

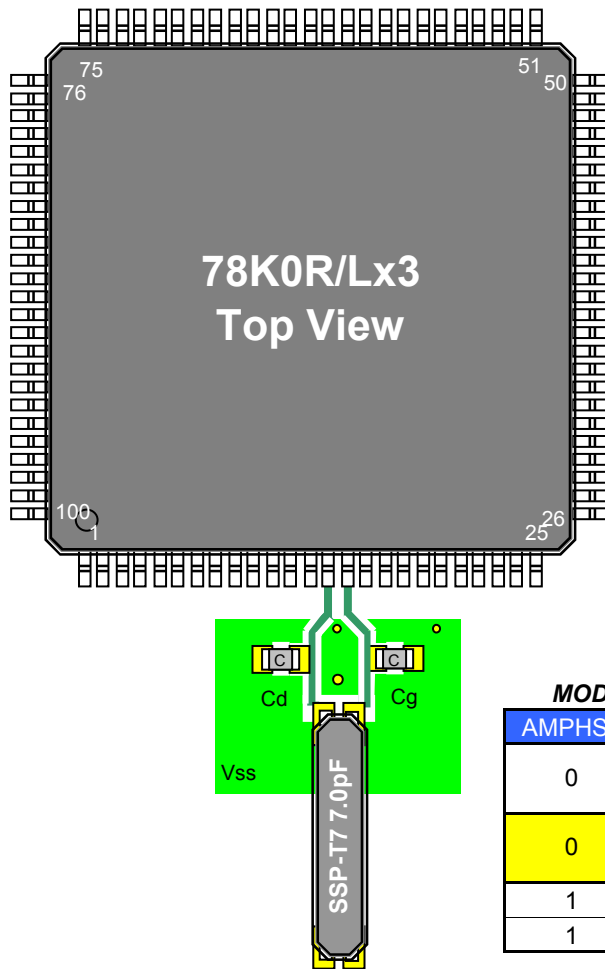

78K0R/Lx3 series

- uPD78F1500
- uPD78F1501
- uPD78F1502
- uPD78F1503
- uPD78F1504
- uPD78F1505
- uPD78F1506
- uPD78F1507
- uPD78F1508

MODEL:SSP-T7 7.0pF with uPD78F1505GC at 25°C

AMPHS1	AMPHS0	Oscillation mode selection
0	0	Low consumption oscillation mode.(default) ; Id=240nA typ.
0	1	Normal consumption oscillation mode. Id=420nA typ.
1	0	Extremely low consumption oscillation mode. *N/R
1	1	Extremely low consumption oscillation mode. *N/R

***N/R: Not recommended.(underestimated gain at 7.0pF)**

Figure 1 Referential components layout

Notes for Board Design

When using a crystal resonator, place the resonator and its load capacitors as close as possible to SUB_in and SUB_out pins.

Other signal lines should be routed away from the resonator circuit to prevent induction from interfering with correct oscillation (see figure 2).

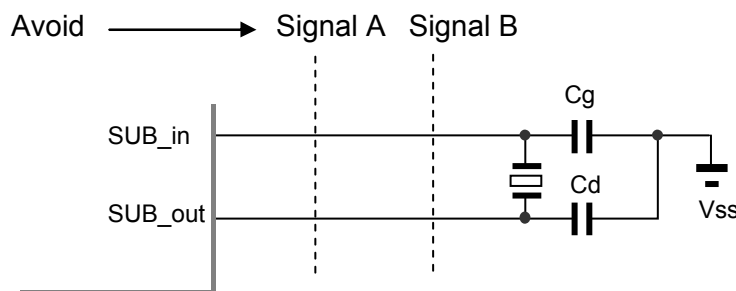

Figure 2 Example of Incorrect Board Design

Remark When using the subsystem clock, insert a resistor, Rd, in series on the SUB_out side.

Evaluation of a Low Frequency Clock Oscillation Circuit

SSP-T7 7.0pF with uPD78F1505GC-16BT [LQFP(14x14) 0.5mm pitch]

Measurement conditions : 3.0V



Normal current consumption mode

[Evaluation Sample at 25°C]

SAMPLE	No.	CL(pF)	Fo(Hz)	fr(Hz)	R1(kΩ)	Co(pF)	C1(fF)	Q(k)
SSP-T7	1	7.0	32768.00	32763.63	37.8	0.90	2.107	61.0
	2	7.0	32768.03	32763.64	39.4	0.91	2.118	58.2
	3	7.0	32768.11	32763.76	42.6	0.91	2.100	54.3

[IC Test Data : IC sample Rd=0Ω,Cg=10pF,Cd=10pF at 25°C]

MODE	IC sample	Fosc(Hz)	df / f(x10 ⁻⁶)	DL(μW)	M(times)	XT2(Vpp)	Id(nA)	Vstart(V)	Ts(sec)
Mode 1	Sample 1	32768.10	3.4	0.03	12	0.94	440	1.61	0.85
	Sample 2	32768.09	3.0	0.03	11	0.94	444	1.59	0.84
	Sample 3	32768.07	2.5	0.02	11	0.90	426	1.59	0.74
	Sample 4	32768.08	2.6	0.02	12	0.85	402	1.60	0.74
	Sample 5	32768.07	2.5	0.02	13	0.82	388	1.59	0.71

[IC Test Data : IC sample Rd=0Ω,Cg=10pF,Cd=10pF at 25°C]

MODE	IC sample	Fosc(Hz)	df / f(x10 ⁻⁶)	DL(μW)	M(times)	XT2(Vpp)	Id(nA)	Vstart(V)	Ts(sec)
Mode 2	Sample 1	32768.10	3.3	0.03	12	0.94	440	1.63	0.85
	Sample 2	32768.09	2.9	0.03	11	0.94	444	1.61	0.84
	Sample 3	32768.07	2.4	0.02	11	0.90	427	1.60	0.74
	Sample 4	32768.07	2.5	0.02	12	0.85	403	1.61	0.74
	Sample 5	32768.07	2.4	0.02	13	0.82	388	1.62	0.71

Remark (see figure 3)

$$F_o = f_r \times \{ C_1 / (2 \times (C_o + C_L)) + 1 \} \text{ (Hz)}$$

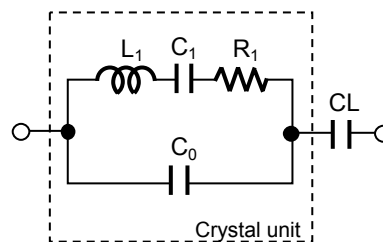

Fo : Load resonance frequency
fr : Resonance frequency
R1 : Motional resistance
C1 : Motional capacitance
Co : Shunt capacitance
CL : Load Capacitance

Figure 3 Equivalent circuit of crystal unit, and CL**Remark (see figure 4)**

Approximate formula of the load capacitance of the circuit CL,

$$C_L = C_g \times C_d / (C_g + C_d) + C_s \text{ (pF)}$$

$$C_s = C_{g_s} \times C_{d_s} / (C_{g_s} + C_{d_s}) + C_{o_s} \text{ (pF)}$$

where Cs(1.5 to 2.5pF) stands for stray capacitance of the circuit.

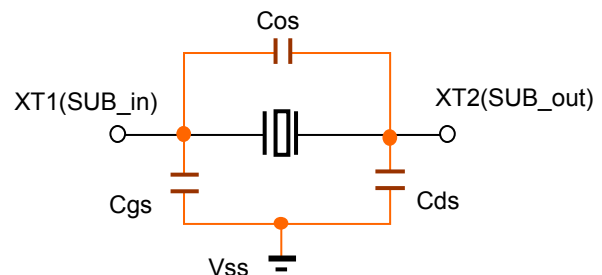

Cos : X1_X2 Stray capacitance
Cgs : X1_Vss Stray capacitance
Cds : X2_Vss Stray capacitance

Figure 4 Stray capacitance Cos,Cgs,Cds of the circuit

Resonator circuit constants differ depending on the resonator element, stray capacitance in its interconnecting circuit, and other factors. Suitable constants should be determined in consultation with the resonator element manufacturer.



Evaluation of a Low Frequency Clock Oscillation Circuit

SSP-T7 7.0pF with uPD78F1505GC-16BT [LQFP(14x14) 0.5mm pitch]

Measurement conditions : Vcc=(1.6V) to (6.0V) at 25°C



Normal current consumption mode

Referential Data(1) : Voltage characteristics

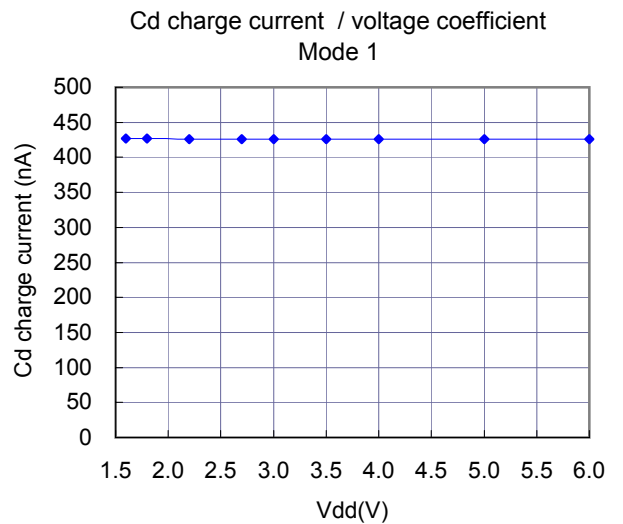
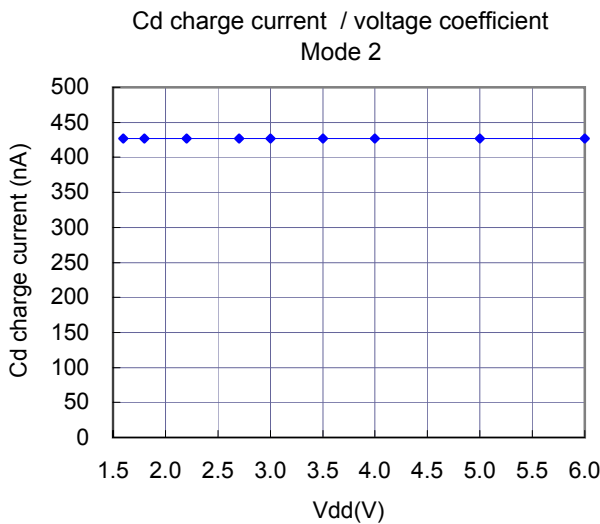
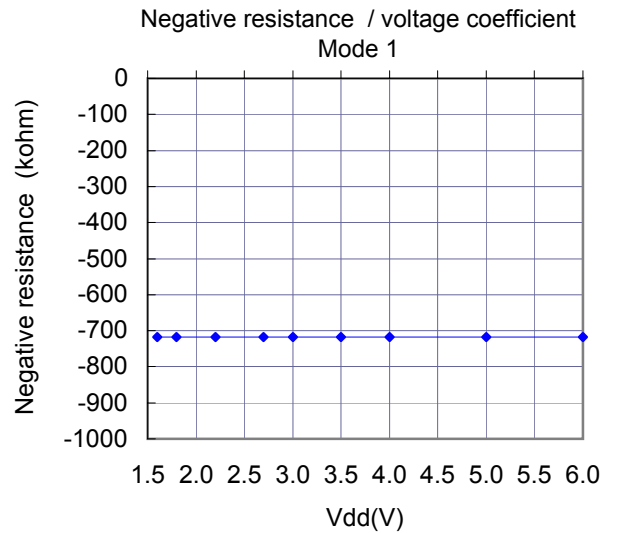
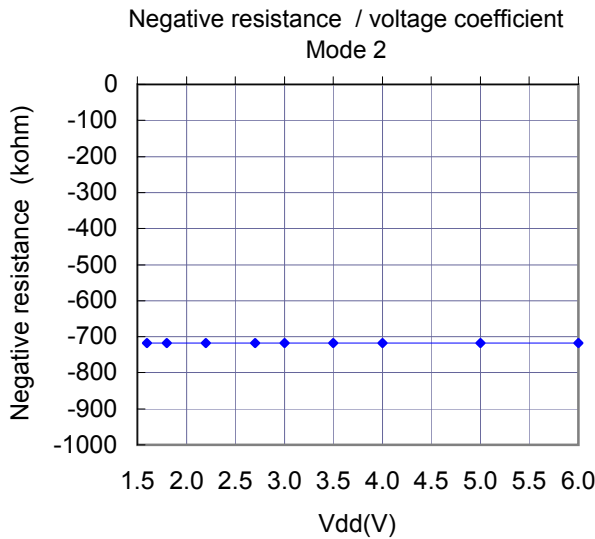
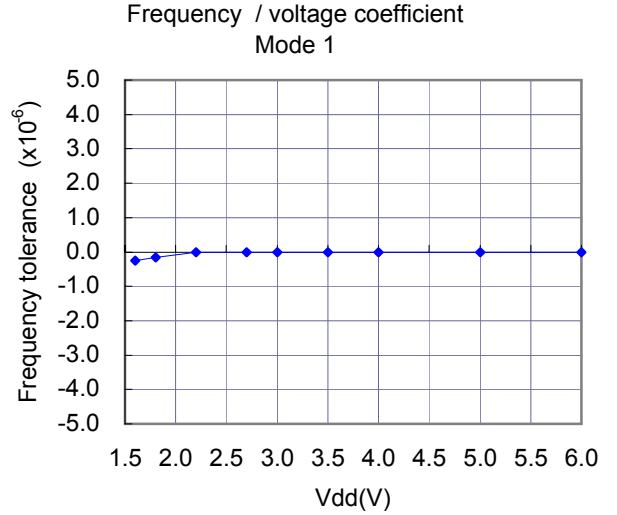
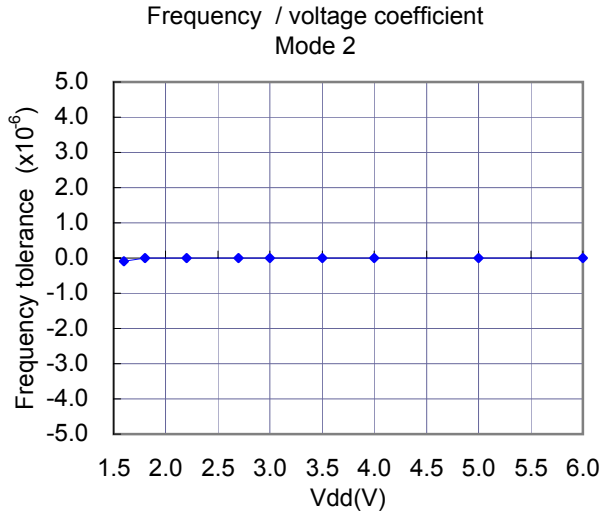

Evaluation of a Low Frequency Clock Oscillation Circuit

SSP-T7 7.0pF with uPD78F1505GC-16BT [LQFP(14x14) 0.5mm pitch]

Measurement conditions : Vcc=(1.6V) to (6.0V) at 25°C



Normal current consumption mode

Referential Data(2) : Voltage characteristics

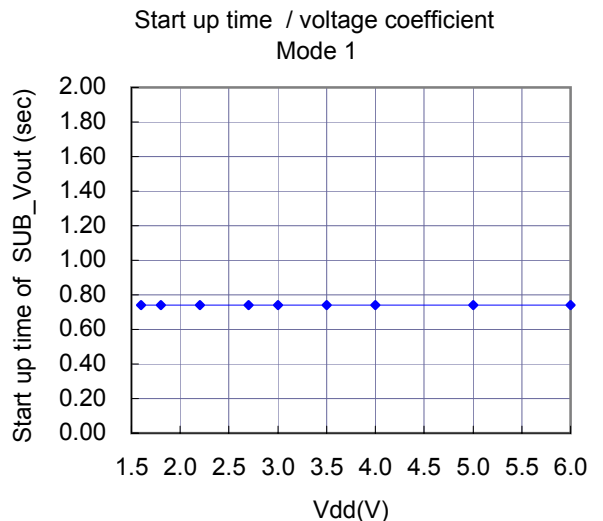
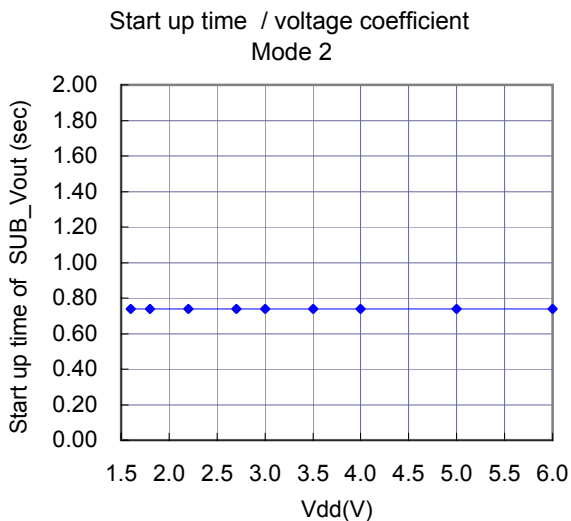
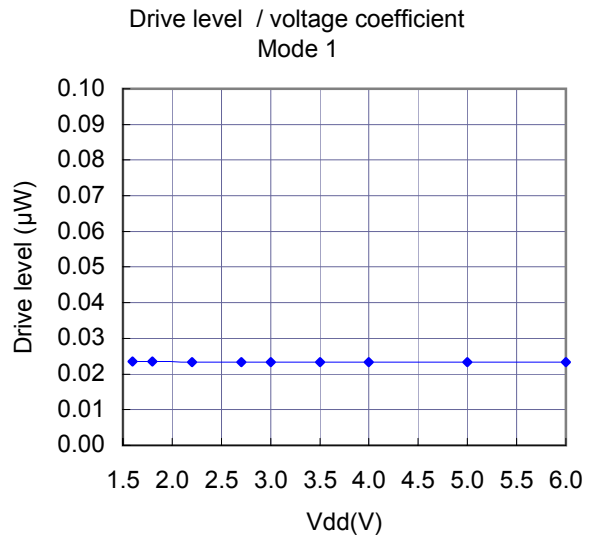
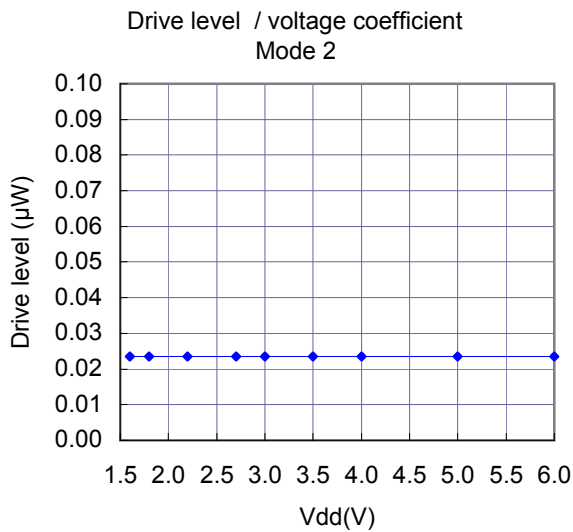
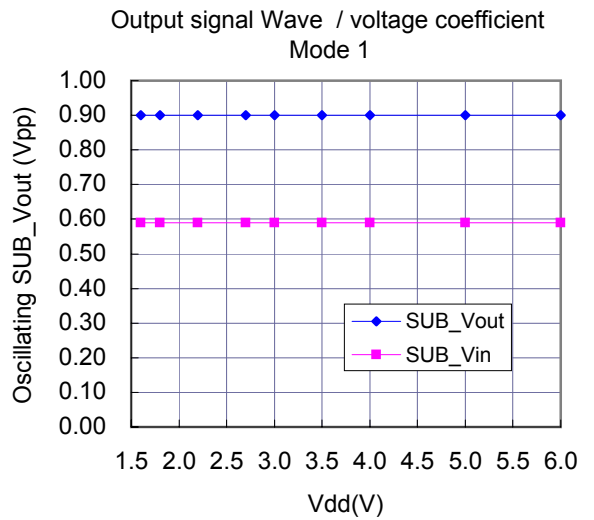
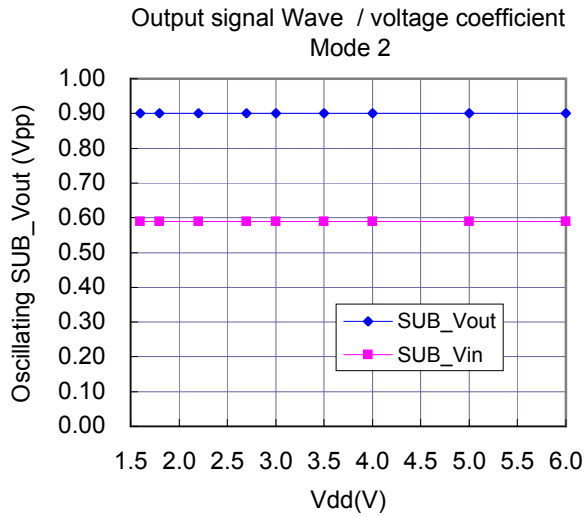

Evaluation of a Low Frequency Clock Oscillation Circuit

SSP-T7 7.0pF with uPD78F1505GC-16BT [LQFP(14x14) 0.5mm pitch]

Measurement conditions : Vdd=3.0V at 25°C



Normal current consumption mode

Referential Data(4) : Load capacitance characteristics

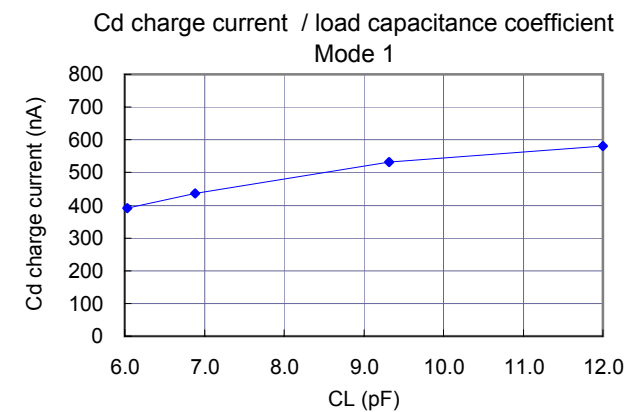
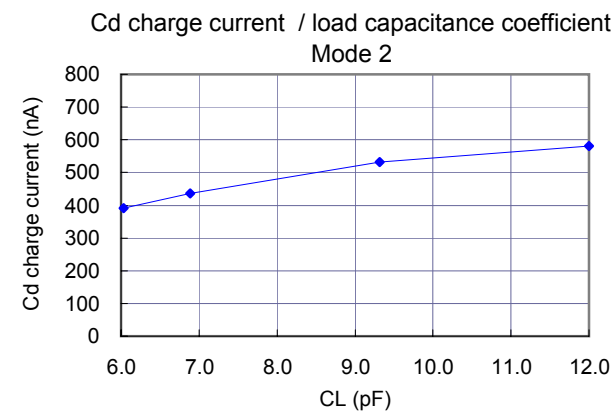
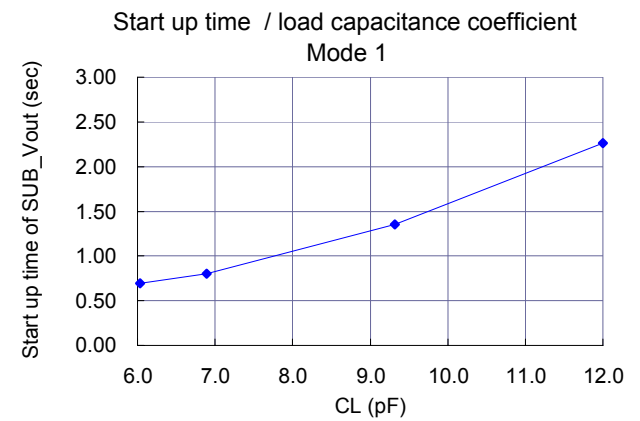
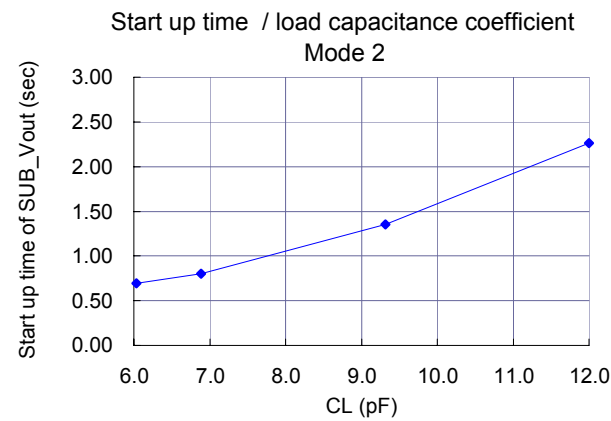
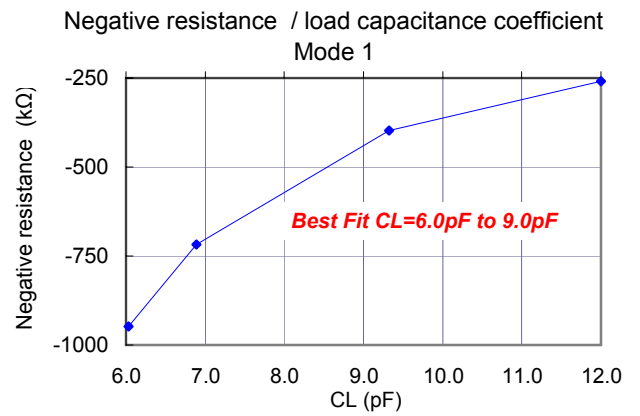
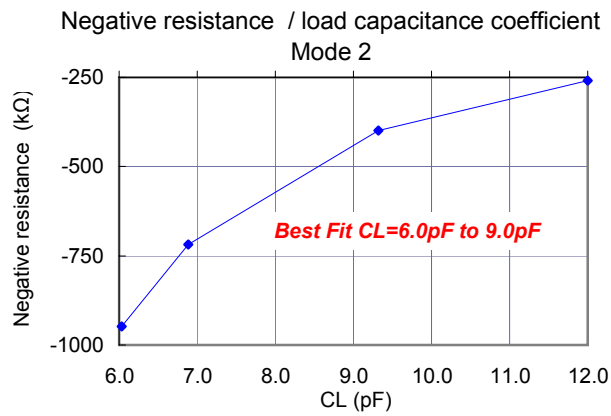
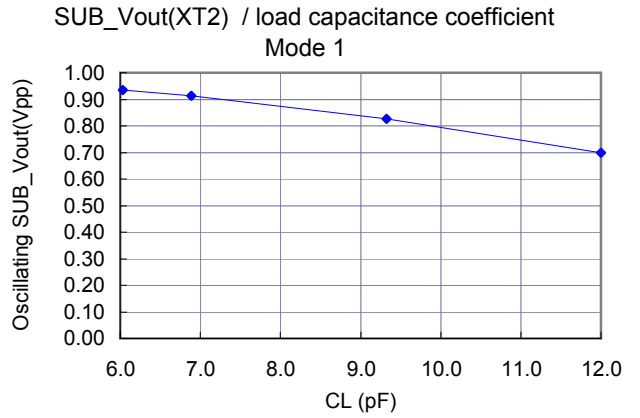
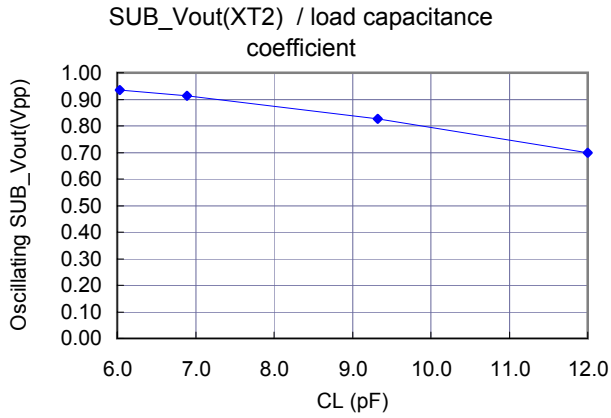

Evaluation of a Low Frequency Clock Oscillation Circuit

SSP-T7 7.0pF with uPD78F1505GC-16BT [LQFP(14x14) 0.5mm pitch]

Measurement conditions : V_{dd}=3.0V at 25°C



Normal current consumption mode

Referential Data(5) : Selection of XT1 oscillation mode and recommended load capacitance

For 78K0R/Lx3 series

XT1 oscillation circuit has the function (via software) to select the XT1 oscillation mode.

The XT1 oscillation mode can be switched over just one time among normal oscillation (Normal), low consumption oscillation (Low), and "extremely low consumption oscillation" mode (E-Low).

Correlations between the oscillation mode selection of XT1 oscillation circuit and the recommended load capacitance for a resonator are shown in Table 1 for safety use.

SSP-T7 series

SSP-T7-FL CL=3.7pF, 4.4pF, 6.0pF and SSP-T7-F CL=7.0pF, 9.0pF

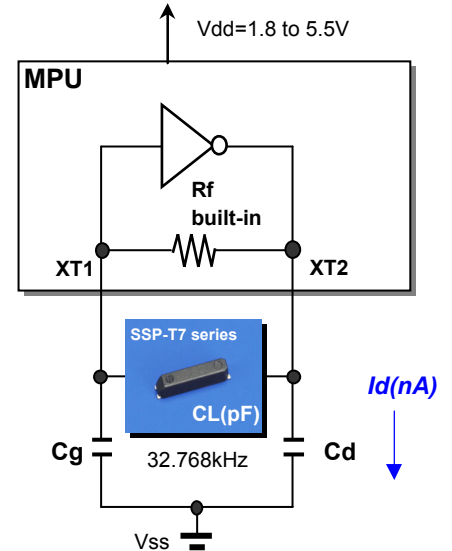
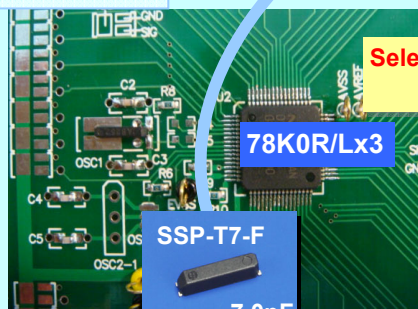

Table 1 Oscillation mode selection of XT1 oscillation circuit and load capacitance for a resonator

XT1 oscillation mode selection	Recommended circuit constant and load capacitance for a resonator				
	C _g =4pF, C _d =3pF	C _g =5pF, C _d =5pF	C _g =9pF, C _d =8pF	C _g =10pF, C _d =10pF	C _g =15pF, C _d =15pF
E-Low Extremely low consumption oscillator	SSP-T7-FL 3.7pF <i>Id=85nA typ</i> <i>RL=-950kΩ typ</i> <i>Ts=0.75sec typ</i>	SSP-T7-FL 4.4pF <i>Id=100nA typ</i> <i>RL=-700kΩ typ</i> <i>Ts=0.95sec typ</i>	SSP-T7-FL 6.0pF <i>Id=120nA typ</i> <i>RL=-395kΩ typ</i> <i>Ts=1.50sec typ</i>	<i>Not recommended.</i>	<i>Not recommended.</i>
Low Low consumption oscillator	<i>Not recommended.</i>	SSP-T7-FL 4.4pF <i>Id=185nA typ</i> <i>RL=-965kΩ typ</i> <i>Ts=0.70sec typ</i>	SSP-T7-FL 6.0pF <i>Id=220nA typ</i> <i>RL=-620kΩ typ</i> <i>Ts=0.95sec typ</i>	SSP-T7-F 7.0pF <i>Id=240nA typ</i> <i>RL=-480kΩ typ</i> <i>Ts=1.20sec typ</i>	<i>Not recommended.</i>
Normal Normal oscillation	<i>Not recommended.</i>	<i>Not recommended.</i>	SSP-T7-FL 6.0pF <i>Id=380nA typ</i> <i>RL=-1050kΩ typ</i> <i>Ts=0.65sec typ</i>	SSP-T7-F 7.0pF <i>Id=420nA typ</i> <i>RL=-770kΩ typ</i> <i>Ts=0.80sec typ</i>	SSP-T7-F 9.0pF <i>Id=530nA typ</i> <i>RL=-400kΩ typ</i> <i>Ts=1.35sec typ</i>

NEC MPU 78K0R/Lx3 series

uPD78F1500, uPD78F1501
uPD78F1502, uPD78F1503
uPD78F1504, uPD78F1505
uPD78F1506, uPD78F1507
uPD78F1508



Low oscillation mode
Id=220nA, RL=-620kΩ

Selection of XT1 oscillation mode and Recommended load capacitance



Extremely low oscillation mode
Id=85nA, RL=-950kΩ

Normal oscillation mode
Id=420nA, RL=-770kΩ